

# Rosemount 8800D Series Vortex Flowmeter

## **HART® AND FOUNDATION™ FIELD BUS PROTOCOLS**

- Available with optional MultiVariable output and temperature compensated mass flow for saturated steam.
- Available in wafer, flanged, dual, reducer and high pressure designs.
- Only manufacturer of Reducer™ Vortex which extends the measurable flow range, reduces installation costs, and minimizes project risk.
- All-welded, non-clog design eliminates ports and gaskets.
- Patented Adaptive Digital Signal Processing (ADSP) provides vibration immunity.
- Unique isolated sensor design allows replacement without breaking the process seal.
- Simplified troubleshooting through device diagnostics.

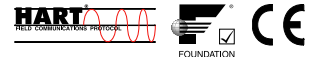

## **Contents**

Specifications .....	page Flow-6
Product Certifications .....	page Flow-22
Dimensional Drawings .....	page Flow-29
Ordering Information .....	page Flow-44

### THE ROSEMOUNT 8800D DELIVERS RELIABILITY

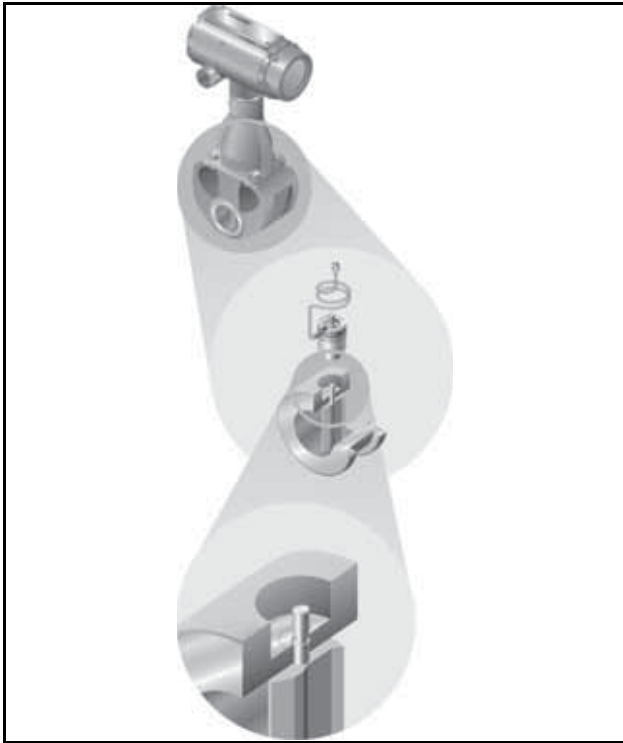

- **Rosemount Reliability** -The 8800D Vortex eliminates impulse lines, ports, and gaskets to improve reliability.
- **Non-clog Design** - Unique gasket-free construction which has no ports that can clog.
- **Vibration Immunity** - Mass Balancing of the sensor system, and Patented Adaptive Digital Signal Processing (ADSP) provide Vibration immunity.
- **Replaceable Sensor** - The sensor is isolated from the process and can be replaced without breaking the process seals. All line sizes use the same sensor design allowing a single spare to serve every meter.
- **Simplified Troubleshooting** - Device Diagnostics enable field verification of Meter Electronics and Sensor with no process shutdown.

### THE ROSEMOUNT 8800D OFFERING

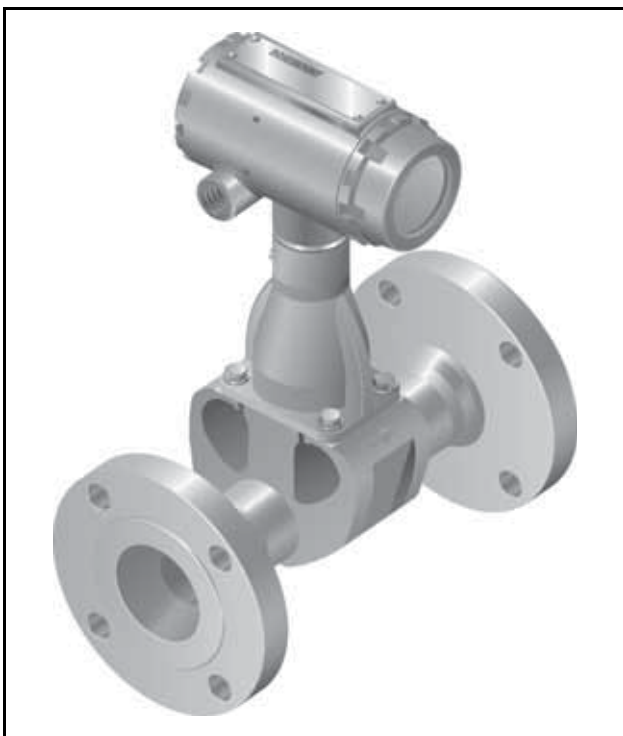

- The 8800D is available in wafer style meter bodies for 1/2 through 8 in. line sizes, and ASME B16.5 (ANSI), DIN, or JIS flanged style meter bodies for 1/2 through 12 in. line sizes.
- Alignment rings, provided with each wafer-style flowmeter, ensure that the meter body is properly centered with the adjacent piping.
- Both wafer and flanged style meter bodies are available in 316L stainless steel and nickel alloy materials of construction.
- Available up to ANSI class 1500 for 1 through 8 in. (25 mm through 200 mm) and ANSI class 900 for 1/2 in. (15 mm) through 8 in. (200 mm).
- Available with FOUNDATION fieldbus functionality which includes Device Diagnostics and PlantWeb Alerts.



## THE ROSEMOUNT 8800DR REDUCER™ VORTEX EXTENDS THE MEASURABLE FLOW RANGE AT A REDUCED COST

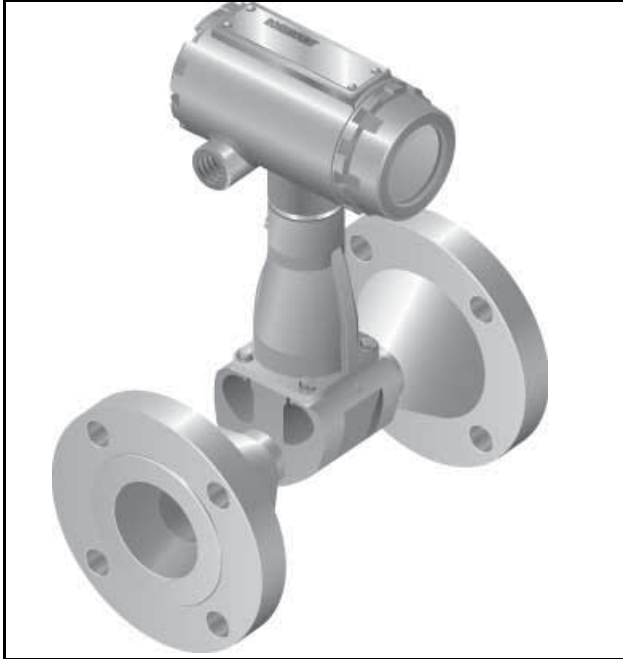

- **Rosemount Reliability** - Designed with same electronics, sensor, and meter body as the 8800D.
- **Reduced Cost** - Eliminates field assembly and welding of separate reducers and piping reducing installed cost by as much as 50%.
- **Extended Measurable Flow** - Low-end flow range is doubled with the Rosemount 8800DR Reducer Vortex.
- **Reduced Project Risk** - Reducer Vortex and the Standard Vortex have the same face-to-face dimension. As a result either meter can be used without affecting pipe layout.
- Available as flanged meter for 1 through 12 in. stainless steel and nickel alloy materials of construction.
- Available with FOUNDATION fieldbus functionality.

## THE DUAL-SENSOR VORTEX FLOWMETER

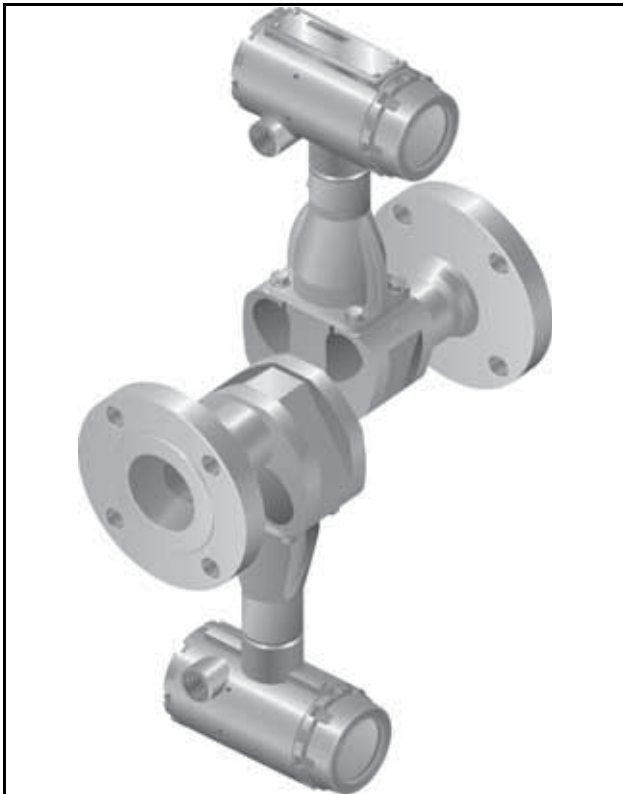

- **Safety Integrated Systems (SIS)** - Ideal solution where redundant flow signals are required.
- **Rosemount Reliability** - Designed with same electronics, sensor, and meter body as the 8800D.
- **Redundant Flow Measurement** - Dual Vortex meter is constructed of two complete vortex meters: sensor, electronics, and shedder bar<sup>(1)</sup>. The meters are welded together and flow calibrated to provide an accurate single flowmeter with two independent flow measurements.
- Available as flanged meter for 1/2 through 12 in. stainless steel and nickel alloy materials of construction.

(1) All 10 in (250 mm) and 12 in (300 mm) dual style vortex meters have a single shedder bar. 6 in (150 mm) and 8 in (200 mm) dual style vortex meters with 900# or 1500# flange ratings have a single shedder bar.

## 8800D MULTIVARIABLE VORTEX REDUCES INSTALLATION COSTS, SIMPLIFIES INSTALLATION, AND IMPROVES PERFORMANCE IN SATURATED STEAM



- **MultiVariable Vortex Design**  
Incorporates temperature sensor into the vortex meter using the shedder bar as a thermowell, which keeps the vortex and temperature sensor isolated from process for easy verification and replacement.
- **Temperature Compensated Capability for Saturated Steam**  
Calculates density from measured process temperature and uses the calculated density to provide a temperature compensated mass flow.
- **Increased performance in Saturated Steam**  
Performance in saturated steam is improved due to the fact that the electronics will be compensating for changes in the process temperature.
- **Reduces Installed Costs**  
MultiVariable Vortex eliminates the need for an external thermowell and temperature sensor.
- **Output Options**  
Can map independent variables to analog output, pulse output, or HART burst variables.
- **Available with Flow Computer for additional functionality**  
Integrate the MultiVariable Vortex with a pressure transmitter for full pressure and temperature compensation of superheated steam and various gases.
- **Remote Mount Electronics**  
Also available with remote mounted electronics up to 75 ft. (23 m)

When you integrate the MultiVariable Vortex with a Rosemount Flow Computer, you get:

- Remote Communications
- Heat Calculations
- Remote Totalization
- Peak Demand Calculation
- Datalogging Capabilities

*Please see Product Data Sheet 00813-0100-4005 for more information on the Rosemount Flow Computer.*



## **ROSEMOUNT 8800D VORTEX FLOWMETER WITH FOUNDATION FIELDBUS**

The software for the 8800D Flowmeter with FOUNDATION fieldbus permits remote testing and configuration using any FOUNDATION fieldbus-compliant host, such as the DeltaV system from Emerson Process Management.

### **Transducer Block**

The transducer block calculates flow from sensor frequency. The calculation includes information about damping, shedding frequency, K-factor, service type, pipe ID, and diagnostics.

### **Resource Block**

The resource block contains physical transmitter information, including available memory, manufacturer identification, device type, software tag, and unique identification.

### **Backup Link Active Scheduler (LAS)**

The transmitter is classified as a device link master. A device link master can function as a Link Active Scheduler (LAS) if the current link master device fails or is removed from the segment.

The host or other configuration tool is used to download the schedule for the application to the link master device. In the absence of a primary link master, the transmitter will claim the LAS and provide permanent control for the H1 segment.

### **Diagnostics**

The transmitter automatically performs continuous self-diagnostics. The user can perform on-line testing of the transmitter digital signal. Advanced simulation diagnostics are available. This enables remote verification of the electronics via a flow signal generator built into the electronics. The sensor strength value can be used to view the process flow signal and provide information regarding filter settings.

## **FOUNDATION Fieldbus Function Blocks**

### **Analog Input**

The AI function block processes the measurement and makes it available to other function blocks. The AI function block also allows filtering, alarming, and engineering unit changes.

The 8800D Flowmeter with FOUNDATION fieldbus comes standard with two AI function blocks (1 block for flow and 1 block for signal strength).

### **Proportional/Integral/Derivative**

The optional PID function block provides a sophisticated implementation of the universal PID algorithm. The PID function block features input for feed forward control, alarms on the process variable, and control deviation. The PID type (series or Instrument Society of America [ISA]) is user-selectable on the derivative filter.

### **Integrator**

The standard integrator block is available for totalization of flow.

### **Setup**

Basic setup requires connecting the transmitter to a fieldbus network or 375 Handheld Communicator. The FOUNDATION fieldbus-compliant host will automatically establish communication with the device.

The Rosemount 8800D Flowmeter can be easily configured using the DeltaV system.

User-configurable parameters include: tag, scaling and units, service type, damping, process density, pipe inside diameter (ID)<sup>(1)</sup>, and process temperature<sup>(1)</sup>.

Tagging information can be entered into the transmitter to allow identification and a physical description. 32-character tags are provided for identification of the transmitter and each function block.

---

(1) *Process temperature and pipe ID have known effects on the K-factor. The 8800D software automatically accounts for these effects by compensating the K-factor.*

## Specifications

The following specifications are for the Rosemount 8800D, Rosemount 8800DR, and Rosemount 8800DD, except where noted.

### FUNCTIONAL SPECIFICATIONS

#### Service

Liquid, gas, and steam applications. Fluids must be homogeneous and single-phase.

#### Line Sizes

##### Wafer

1/2, 1, 1 1/2, 2, 3, 4, 6, and 8 inches  
(DN 15, 25, 40, 50, 80, 100, 150, and 200)

##### Flanged and Dual-Sensor Style

1/2, 1, 1 1/2, 2, 3, 4, 6, 8, 10, and 12 inches  
(DN 15, 25, 40, 50, 80, 100, 150, 200, 250, and 300)

##### Reducer

1, 1 1/2, 2, 3, 4, 6, 8, 10, and 12 inches  
(DN 25, 40, 50, 80, 100, 150, 200, 250, and 300)

#### Pipe Schedules

Process piping Schedules 10, 40, 80, and 160.

#### NOTE

The appropriate bore diameter of the process piping must be entered using the HART Communicator or AMS. Meters will be shipped from the factory at the Schedule 40 default value unless otherwise specified.

#### Measurable Flow Rates

Capable of processing signals from flow applications which meet the sizing requirements below.

To determine the appropriate flowmeter size for an application, process conditions must be within the Reynolds number and velocity limitations for the desired line size provided in Table 1, Table 2, Table 3, and Table 4.

#### NOTE

Consult your local sales representative to obtain a computer sizing program that describes in greater detail how to specify the correct flowmeter size for an application.

The Reynolds number equation shown below combines the effects of density ( $\rho$ ), viscosity ( $\mu_{cp}$ ), pipe inside diameter ( $D$ ), and flow velocity ( $V$ ).

$$R_D = \frac{VD\rho}{\mu_{cp}}$$

TABLE 1. Minimum Measurable Meter Reynolds Numbers

Meter Sizes (Inches / DN)	Reynolds Number Limitations
1/2 through 4/15 through 100	10000 minimum
6 through 12/150 through 300	20000 minimum

TABLE 2. Minimum Measurable Meter Velocities<sup>(1)</sup>  
(Use the larger of the two values)

	Feet per Second	Meters per Second
Liquids <sup>(2)</sup>	$\sqrt{36/\rho}$ or 0.7	$\sqrt{54/\rho}$ or 0.22
Gases	$\sqrt{36/\rho}$ or 6.5	$\sqrt{54/\rho}$ or 2.0

The  $\rho$  is the process fluid density at flowing conditions in lb/ft<sup>3</sup> for ft/s and kg/m<sup>3</sup> for m/s

(1) Velocities are referenced to schedule 40 pipe.

(2) The minimum measurable velocity for the 10in. line size is 0.94 ft/s (.29m/s) and 1.11 ft/s (.34m/s) for the 12in. line size.

TABLE 3. Maximum Measurable Meter Velocities<sup>(1)</sup>  
(Use the smaller of the two values)

	Feet per Second	Meters per Second
Liquids	$\sqrt{90,000/\rho}$ or 25	$\sqrt{134,000/\rho}$ or 7.6
Gases <sup>(2)</sup>	$\sqrt{90,000/\rho}$ or 250	$\sqrt{134,000/\rho}$ or 76

The  $\rho$  is the process fluid density at flowing conditions in lb/ft<sup>3</sup> for ft/s and kg/m<sup>3</sup> for m/s

(1) Velocities are referenced to schedule 40 pipe.

(2) Accuracy limitations for gas and steam for Dual-style meters (1/2" to 8"): max velocity of 100 ft/s (30.5 m/s).

## Product Data Sheet

00813-0100-4004, Rev FA  
Catalog 2008 - 2009

# Rosemount 8800D

### Process Temperature Limits

#### Standard

–40 to 450 °F (–40 to 232 °C)

#### Extended

–330 to 800 °F (–200 to 427 °C)

#### MultiVariable (MTA option)

–40 to 800 °F (–40 to 427 °C)

★ Use above 450 °F (232 °C) requires Extended Sensor

### Output Signals

#### 4–20 mA Digital HART Signal

Superimposed on 4–20 mA signal

#### Optional Scalable Pulse Output

0 to 10000 Hz; transistor switch closure with adjustable scaling via HART communications; capable of switching up to 30 V dc, 120 mA maximum

#### Digital Foundation fieldbus signal

Manchester-encoded digital signal that conforms to IEC 1158-2 and ISA 50.02.

### Analog Output Adjustment

Engineering units and lower and upper range values are user-selected. Output is automatically scaled to provide 4 mA at the selected lower range value, 20 mA at the selected upper range value. No frequency input is required to adjust the range values.

### Scalable Frequency Adjustment

The scalable pulse output can be set to a specific velocity, volume, or mass (i.e. 1 pulse = 1 lb). The scalable pulse output can also be scaled to a specific rate of volume, mass, or velocity (i.e. 100 Hz = 500 lb/hr).

### Ambient Temperature Limits

#### Operating

–58 to 185 °F (–50 to 85 °C)

–4 to 185 °F (–20 to 85 °C) for flowmeters with local indicator

#### Storage

–58 to 250 °F (–50 to 121 °C)

–50 to 185 °F (–46 to 85 °C) for flowmeters with local indicator

### Pressure Limits

#### Flange Style Meter

Rated for ASME B16.5 (ANSI) Class 150, 300, 600, 900, and 1500, DIN PN 10, 16, 25, 40, 64, 100, and 160, and JIS 10K, 20K, and 40K

#### Reducer Style Meter

Rated for ASME B16.5 (ANSI) Class 150, 300, 600, and 900, DIN PN 10, 16, 25, 40, 64, 100, and 160.

#### Dual Sensor Style Meter

Rated for ASME B16.5 (ANSI) Class 150, 300, 600, 900, and 1500, DIN PN 10, 16, 25, 40, 64, 100, and 160, and JIS 10K, 20K, and 40K

#### Wafer Style Meter

Rated for ASME B16.5 (ANSI) Class 150, 300, and 600, DIN PN 10, 16, 25, 40, 64, and 100, and JIS 10K, 20K, and 40K

#### Weld-End Style Meter

W1 Welds to Schedule 10 mating pipe

Max Working Pressure 720 psig (4.96 MPa-g)

W4 Welds to Schedule 40 mating pipe

Max Working Pressure 1440 psig (9.93 MPa-g)

W8 Welds to Schedule 80 mating pipe

Max Working Pressure 2160 psig (14.9 MPa-g)

W9 Welds to Schedule 160 mating pipe

Note: 1" (25 mm), and 1.5" (40 mm) weld to Schedule 80 mating pipe

Max Working Pressure 3600 psig (24.8 MPa-g)

### Power Supply

#### HART Analog

External power supply required. Flowmeter operates on 10.8 to 42 V dc terminal voltage (with 250-ohm minimum load required for HART communications, 16.8 V dc power supply is required)

#### Foundation fieldbus

External power supply required. Flowmeter operates on 9 to 32 V dc, 17.8 mA nominal, 20.0 mA maximum.

### Power Consumption

One watt maximum

### Load Limitations (HART Analog)

Maximum loop resistance is determined by the voltage level of the external power supply, as described by:

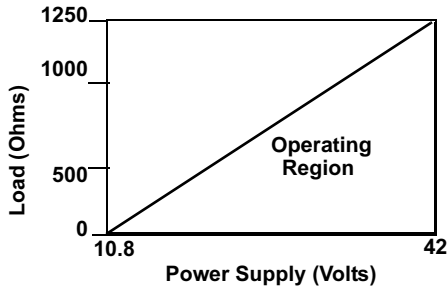

$$R_{\max} = 41.7(V_{\text{ps}} - 10.8)$$

$V_{\text{ps}}$  = Power Supply Voltage (Volts)  
 $R_{\max}$  = Maximum Loop Resistance (Ohms)

### NOTE

HART Communication requires a minimum loop resistance of 250 ohms.

### Optional LCD Indicator

The optional LCD indicator is capable of displaying:

- Primary Variable
- Velocity Flow
- Volumetric Flow
- Mass Flow
- Percent of Range
- Analog Output (if applicable)
- Totalizer (Output Code "D" and "P" Only)
- Shedding Frequency
- Pulse Output Frequency (if applicable)
- Electronics Temperature (Output Code "D" and "P" Only)
- Process Temperature (MTA Option Only)
- Calculated Process Density (MTA Option Only)

If more than one item is selected, the display will scroll through all items selected.

### Enclosure Rating

FM Type 4X; CSA Type 4X; IP66

### Permanent Pressure Loss

The approximate permanent pressure loss (PPL) from the Rosemount 8800D flowmeter is calculated for each application in the Vortex sizing software available from your local Rosemount representative. The PPL is determined using the equation:

$$PPL = \frac{A \times \rho_f \times Q^2}{D^4}$$

where:

PPL = Permanent Pressure loss (psi or kPa)

Where:

$\rho_f$  = Density at operating conditions (lb/ft<sup>3</sup> or kg/m<sup>3</sup>)

Q = Actual volumetric flow rate (Gas = ft<sup>3</sup>/min or m<sup>3</sup>/hr; Liquid = gal/min or l/min)

D = Flowmeter bore diameter (in. or mm)

A = Constant depending on meter style, fluid type and flow units. Determined per following table:

TABLE 4. Determining the PPL

Meter Style	English Units		SI Units	
	A <sub>Liquid</sub>	A <sub>Gas</sub>	A <sub>Liquid</sub>	A <sub>Gas</sub>
8800DFW	$3.4 \times 10^{-5}$	$1.9 \times 10^{-3}$	0.425	118
8800DR	$3.91 \times 10^{-5}$	$2.19 \times 10^{-3}$	0.489	136
8800DD <sup>(1)</sup>	$6.12 \times 10^{-5}$	$3.42 \times 10^{-3}$	0.765	212

(1) For all 10 and 12 in (250 and 300 mm) line sizes and 6 and 8 in (150 and 200 mm) with 900# or 1500# Flanges, A for Rosemount 8800DD is the same as Rosemount 8800DF.

### Minimum Back Pressure (Liquids)

Flow metering conditions that would allow cavitation, the release of vapor from a liquid, should be avoided. This flow condition can be avoided by remaining within the proper flow range of the meter and by following appropriate system design.

For some liquid applications, incorporation of a back pressure valve should be considered. To prevent cavitation, the minimum back pressure should be:

$$P = 2.9 \cdot \Delta P + 1.3 \cdot p_v \text{ or } P = 2.9 \cdot \Delta P + p_v + 0.5 \text{ psia} \quad (3.45 \text{ kPa}) \text{ (use the smaller of the two results)}$$

P = Line pressure five pipe diameters downstream of the meter (psia or kPa abs)

$\Delta P$  = Pressure loss across the meter (psi or kPa)

$p_v$  = Liquid vapor pressure at operating conditions (psia or kPa abs)



## Product Data Sheet

00813-0100-4004, Rev FA  
Catalog 2008 - 2009

# Rosemount 8800D

### Failure Mode Alarm

#### HART Analog

If self-diagnostics detect a gross flowmeter failure, the analog signal will be driven to the values below:

Low	3.75
High	22.6
NAMUR Low	3.60
NAMUR High	22.6

High or low alarm signal is user-selectable through the fail mode alarm jumper on the electronics. NAMUR-compliant alarm limits are available through the C4 or CN Option. Alarm type is field configurable also.

#### Foundation fieldbus

The AI block allows the user to configure the alarm to HI-HI, HI, LO, or LO-LO with a variety of priority levels.

### Saturation Output Values

When the operating flow is outside the range points, the analog output continues to track the operating flow until reaching the saturation value listed below; the output does not exceed the listed saturation value regardless of the operating flow. The NAMUR-Compliant Saturation Values are available through the C4 or CN option. Saturation type is field configurable.

Low	3.9
High	20.8
NAMUR Low	3.8
NAMUR High	20.5

### Damping

Flow Damping adjustable between 0.2 and 255 seconds.

Process Temperature Damping adjustable between 4.0 and 32.0 seconds (MTA Option Only).

### Response Time

Three vortex shedding cycles or 300 ms, whichever is greater, maximum required to reach 63.2% of actual input with the minimum damping (0.2 seconds).

### Turn-on Time

#### HART Analog

Less than four (4) seconds plus the response time to rated accuracy from power up (less than 7 seconds with the MTA Option).

#### Foundation fieldbus

Performance within specifications no greater than 10.0 seconds after power is applied.

### Transient Protection

The optional transient terminal block prevents damage to the flowmeter from transients induced by lightning, welding, heavy electrical equipment, or switch gears. The transient protection electronics are located in the terminal block.

The transient terminal block meets the following specifications:

ASME B16.5 (ANSI)/IEEE C62.41 - 1980  
(IEEE 587) Categories A, B  
3 kA crest ( $8 \times 20 \mu\text{s}$ )  
6 kV crest ( $1.2 \times 50 \mu\text{s}$ )  
6 kV/0.5 kA ( $0.5 \mu\text{s}$ , 100 kHz, ring wave)

### Security Lockout

When the security lockout jumper is enabled, the electronics will not allow you to modify parameters that affect flowmeter output.

### Output Testing

#### Current Source

Flowmeter may be commanded to set the current to a specified value between 4 and 20 mA.

#### Frequency Source

Flowmeter may be commanded to set the frequency to a specified value between 0 and 10000 Hz.

### Low Flow Cutoff

Adjustable over entire flow range. Below selected value, output is driven to 4 mA and zero pulse output frequency.

### Humidity Limits

Operates in 0–95% relative humidity under noncondensing conditions (tested to IEC 60770, Section 6.2.11).

## Overrange Capability

### HART Analog

Analog signal output continues to 105 percent of span, then remains constant with increasing flow. The digital and pulse outputs will continue to indicate flow up to the upper sensor limit of the flowmeter and a maximum pulse output frequency of 10400 Hz.

### Foundation fieldbus

For liquid service type, the transducer block digital output will continue to a nominal value of 25 ft/s. After that, the status associated with the transducer block output will go to UNCERTAIN. Above a nominal value of 30 ft/s, the status will go to BAD.

For gas/steam service, the transducer block digital output will continue to a nominal value of 220 ft/s for 0.5 and 1.0 in. line sizes and a nominal value of 250 ft/s for 1.5–12 in. line sizes. After that, the status associated with the transducer block output will go to UNCERTAIN. Above a nominal value of 300 ft/s for all line sizes, the status will go to BAD.

## Flow Calibration

Meter bodies are flow-calibrated and assigned a unique calibration factor (K-factor) at the factory. The calibration factor is entered into the electronics, enabling interchangeability of electronics and/or sensors without calculations or compromise in accuracy of the calibrated meter body.

### Status (FOUNDATION fieldbus only)

If self-diagnostics detect a transmitter failure, the status of the measurement will inform the control system. Status may also set the PID output to a safe value.

### Schedule Entries (FOUNDATION fieldbus only)

Six (6)

### Links (FOUNDATION fieldbus only)

Twelve (12)

## Virtual Communications Relationships (VCRs) (FOUNDATION fieldbus only)

Two (2) predefined (F6, F7)

Four (4) configured (see Table 5)

TABLE 5. Block Information.

Block	Base Index	Execution Time (Milliseconds)
Resource (RB)	300	—
Transducer (TB)	400	—
Analog Input (AI)	1,000	20
Proportional/ Integral/Derivative (PID)	10,000	30
Integrator (INT)	12,000	20

# Product Data Sheet

00813-0100-4004, Rev FA

Catalog 2008 - 2009

# Rosemount 8800D

TABLE 6. Typical pipe velocity ranges for 8800D and 8800DR<sup>(1)</sup>

Process Line Size		Liquid Velocity Ranges		Gas Velocity Ranges	
(Inches/ DN)	Vortex Meter <sup>(2)</sup>	(ft/s)	(m/s)	(ft/s)	(m/s)
0.5/ 15	8800DF005	0.70 to 25.0	0.21 to 7.6	6.50 to 250.0	1.98 to 76.2
1/ 25	8800DF010	0.70 to 25.0	0.21 to 7.6	6.50 to 250.0	1.98 to 76.2
	8800DR010	0.25 to 8.8	0.08 to 2.7	2.29 to 87.9	0.70 to 26.8
1.5/ 40	8800DF015	0.70 to 25.0	0.21 to 7.6	6.50 to 250.0	1.98 to 76.2
	8800DR015	0.30 to 10.6	0.09 to 3.2	2.76 to 106.1	0.84 to 32.3
2/ 50	8800DF020	0.70 to 25.0	0.21 to 7.6	6.50 to 250.0	1.98 to 76.2
	8800DR020	0.42 to 15.2	0.13 to 4.6	3.94 to 151.7	1.20 to 46.2
3/ 80	8800DF030	0.70 to 25.0	0.21 to 7.6	6.50 to 250.0	1.98 to 76.2
	8800DR030	0.32 to 11.3	0.10 to 3.5	2.95 to 113.5	0.90 to 34.6
4/ 100	8800DF040	0.70 to 25.0	0.21 to 7.6	6.50 to 250.0	1.98 to 76.2
	8800DR040	0.41 to 14.5	0.12 to 4.4	3.77 to 145.2	1.15 to 44.3
6/ 150	8800DF060	0.70 to 25.0	0.21 to 7.6	6.50 to 250.0	1.98 to 76.2
	8800DR060	0.31 to 11.0	0.09 to 3.4	2.86 to 110.2	0.87 to 33.6
8/ 200	8800DF080	0.70 to 25.0	0.21 to 7.6	6.50 to 250.0	1.98 to 76.2
	8800DR080	0.40 to 14.4	0.12 to 4.4	3.75 to 144.4	1.14 to 44.0
10/ 250	8800DF100	0.90 to 25.0	0.27 to 7.6	6.50 to 250.0	1.98 to 76.2
	8800DR100	0.44 to 15.9	0.13 to 4.8	4.12 to 158.6	1.26 to 48.3
12/ 300	8800DF120	1.10 to 25.0	0.34 to 7.6	6.50 to 250.0	1.98 to 76.2
	8800DR120	0.63 to 17.6	0.19 to 5.4	4.58 to 176.1	1.40 to 53.7

(1) Table 6 is a reference of pipe velocities that can be measured for the standard Rosemount 8800D and the reducer Rosemount 8800DR Vortex Meters. It does not consider density limitations, as described in tables 2 and 3. Velocities are referenced in schedule 40 pipe.

(2) Velocity range of the Rosemount 8800DW is the same as Rosemount 8800DF.

TABLE 7. Water Flow Rate Limits for the Rosemount 8800D and 8800DR<sup>(1)</sup>

Process Line Size		Minimum and Maximum Measurable Water Flow Rates*	
(Inches/ DN)	Vortex Meter <sup>(2)</sup>	Gallons/Minute	Cubic Meters/Hour
0.5/ 15	8800DF005	1.76 to 23.7	0.40 to 5.4
1/ 25	8800DF010	2.96 to 67.3	0.67 to 15.3
	8800DR010	1.76 to 23.7	0.40 to 5.4
1.5/ 40	8800DF015	4.83 to 158	1.10 to 35.9
	8800DR015	2.96 to 67.3	0.67 to 15.3
2/ 50	8800DF020	7.96 to 261	1.81 to 59.4
	8800DR020	4.83 to 158.0	1.10 to 35.9
3/ 80	8800DF030	17.5 to 576	4.00 to 130
	8800DR030	7.96 to 261.0	1.81 to 59.3
4/ 100	8800DF040	30.2 to 992	6.86 to 225
	8800DR040	17.5 to 576	4.00 to 130
6/ 150	8800DF060	68.5 to 2251	15.6 to 511
	8800DR060	30.2 to 992	6.86 to 225
8/ 200	8800DF080	119 to 3898	27.0 to 885
	8800DR080	68.5 to 2251	15.6 to 511
10/ 250	8800DF100	231 to 6144	52.2 to 1395
	8800DR100	119 to 3898	27.0 to 885
12/ 300	8800DF120	391 to 8813	88.8 to 2002
	8800DR120	231 to 6144	52.2 to 1395

\*Conditions: 77 °F (25 °C) and 14.7 psia (1.01 bar absolute)

(1) Table 7 is a reference of flow rates that can be measured for the standard Rosemount 8800D and the reducer 8800DR Vortex Meters. It does not consider density limitations, as described in tables 2 and 3.

(2) Velocity range of the 8800DW is the same as 8800DF.

# Rosemount 8800D

TABLE 8. Air Flow Rate Limits at 59 °F (15 °C)

Process Pressure	Flow Rate Limits	Minimum and Maximum Air Flow Rates for line sizes 1/2 in./DN 15 through 1 in./DN 25							
		1/2 in./DN 15				1 in./DN 25			
		Rosemount 8800D		Rosemount 8800DR		Rosemount 8800D		Rosemount 8800DR	
		ACFM	ACMH	ACFM	ACMH	ACFM	ACMH	ACFM	ACMH
0 psig (0 bar G)	max	27.9	47.3	Not Available	Not Available	79.2	134	27.9	47.3
	min	3.86	6.56			7.81	13.3	3.86	6.56
50 psig (3,45 bar G)	max	27.9	47.3	Not Available	Not Available	79.2	134	27.9	47.3
	min	1.31	2.22			3.72	6.32	1.31	2.22
100 psig (6,89 bar G)	max	27.9	47.3	Not Available	Not Available	79.2	134	27.9	47.3
	min	0.98	1.66			2.80	4.75	0.98	1.66
150 psig (10,3 bar G)	max	27.9	47.3	Not Available	Not Available	79.2	134	27.9	47.3
	min	0.82	1.41			2.34	3.98	0.82	1.41
200 psig (13,8 bar G)	max	27.9	47.3	Not Available	Not Available	79.2	134	27.9	47.3
	min	0.82	1.41			2.34	3.98	0.82	1.41
300 psig (20,7 bar G)	max	27.9	47.3	Not Available	Not Available	79.2	134	27.9	47.3
	min	0.82	1.41			2.34	3.98	0.82	1.41
400 psig (27,6 bar G)	max	25.7	43.9	Not Available	Not Available	73.0	124	25.7	43.9
	min	0.82	1.41			2.34	3.98	0.82	1.41
500 psig (34,5 bar G)	max	23.0	39.4	Not Available	Not Available	66.0	112	23.0	39.4
	min	0.82	1.41			2.34	3.98	0.82	1.41

TABLE 9. Air Flow Rate Limits at 59 °F (15 °C)

Process Pressure	Flow Rate Limits	Minimum and Maximum Air Flow Rates for line sizes 1 1/2 in./DN 40 through 2 in./DN 50							
		1 1/2 in./DN 40				2 in./DN 50			
		Rosemount 8800D		Rosemount 8800DR		Rosemount 8800D		Rosemount 8800DR	
		ACFM	ACMH	ACFM	ACMH	ACFM	ACMH	ACFM	ACMH
0 psig (0 bar G)	max	212	360	79.2	134	349	593	212	360
	min	18.4	31.2	7.81	13.3	30.3	51.5	18.4	31.2
50 psig (3,45 bar G)	max	212	360	79.2	134	349	593	212	360
	min	8.76	14.9	3.72	6.32	14.5	24.6	8.76	14.9
100 psig (6,89 bar G)	max	212	360	79.2	134	349	593	212	360
	min	6.58	11.2	2.80	4.75	10.8	18.3	6.58	11.2
150 psig (10,3 bar G)	max	212	360	79.2	134	349	593	212	360
	min	5.51	9.36	2.34	3.98	9.09	15.4	5.51	9.36
200 psig (13,8 bar G)	max	212	360	79.2	134	349	593	212	360
	min	5.51	9.36	2.34	3.98	9.09	15.4	5.51	9.36
300 psig (20,7 bar G)	max	198	337	79.2	134	326	554	198	337
	min	5.51	9.36	2.34	3.98	9.09	15.4	5.51	9.36
400 psig (27,6 bar G)	max	172	293	73.0	124	284	483	172	293
	min	5.51	9.36	2.34	3.98	9.09	15.4	5.51	9.36
500 psig (34,5 bar G)	max	154	262	66.0	112	254	432	154	262
	min	5.51	9.36	2.34	3.98	9.09	15.4	5.51	9.36

# Product Data Sheet

00813-0100-4004, Rev FA  
 Catalog 2008 - 2009

# Rosemount 8800D

TABLE 10. Air Flow Rate Limits at 59 °F (15 °C)

Process Pressure	Flow Rate Limits	Minimum and Maximum Air Flow Rates for line sizes 3 in./DN 80 through 4 in./DN 100							
		3 in./DN 80				4 in./DN 100			
		Rosemount 8800D		Rosemount 8800DR		Rosemount 8800D		Rosemount 8800DR	
		ACFM	ACMH	ACFM	ACMH	ACFM	ACMH	ACFM	ACMH
0 psig (0 bar G)	max	770	1308	349	593	1326	2253	770	1308
	min	66.8	114	30.3	51.5	115	195	66.8	114
50 psig (3,45 bar G)	max	770	1308	349	593	1326	2253	770	1308
	min	31.8	54.1	14.5	24.6	54.8	93.2	31.8	54.1
100 psig (6,89 bar G)	max	770	1308	349	593	1326	2253	770	1308
	min	23.9	40.6	10.8	18.3	41.1	69.8	23.9	40.6
150 psig (10,3 bar G)	max	770	1308	349	593	1326	2253	770	1308
	min	20.0	34.0	9.09	15.4	34.5	58.6	20.0	34.0
200 psig (13,8 bar G)	max	770	1308	349	593	1326	2253	770	1308
	min	20.0	34.0	9.09	15.4	34.5	58.6	20.0	34.0
300 psig (20,7 bar G)	max	718	1220	326	554	1237	2102	718	1220
	min	20.0	34.0	9.09	15.4	34.5	58.6	20.0	34.0
400 psig (27,6 bar G)	max	625	1062	284	483	1076	1828	625	1062
	min	20.0	34.0	9.09	15.4	34.5	58.6	20.0	34.0
500 psig (34,5 bar G)	max	560	951	254	432	964	1638	560	951
	min	20.0	34.0	9.09	15.4	34.5	58.6	20.0	34.0

TABLE 11. Air Flow Rate Limits at 59 °F (15 °C)

Process Pressure	Flow Rate Limits	Minimum and Maximum Air Flow Rates for line sizes 6 in./DN 150 through 8 in./DN 200							
		6 in./DN 150				8 in./DN 200			
		Rosemount 8800D		Rosemount 8800DR		Rosemount 8800D		Rosemount 8800DR	
		ACFM	ACMH	ACFM	ACMH	ACFM	ACMH	ACFM	ACMH
0 psig (0 bar G)	max	3009	5112	1326	2253	5211	8853	3009	5112
	min	261	443	115	195	452	768	261	443
50 psig (3,45 bar G)	max	3009	5112	1326	2253	5211	8853	3009	5112
	min	124	211	54.8	93.2	215	365	124	211
100 psig (6,89 bar G)	max	3009	5112	1326	2253	5211	8853	3009	5112
	min	93.3	159	41.1	69.8	162	276	93.3	159
150 psig (10,3 bar G)	max	3009	5112	1326	2253	5211	8853	3009	5112
	min	78.2	133	34.5	58.6	135	229	78.2	133
200 psig (13,8 bar G)	max	3009	5112	1326	2253	5211	8853	3009	5112
	min	78.2	133	34.5	58.6	135	229	78.2	133
300 psig (20,7 bar G)	max	2807	4769	1237	2102	4862	8260	2807	4769
	min	78.2	133	34.5	58.6	135	229	78.2	133
400 psig (27,6 bar G)	max	2442	4149	1076	1828	4228	7183	2442	4149
	min	78.2	133	34.5	58.6	136	229	78.2	133
500 psig (34,5 bar G)	max	2188	3717	964	1638	3789	6437	2188	3717
	min	78.2	133	34.5	58.6	136	229	78.2	133

# Rosemount 8800D

TABLE 12. Air Flow Rate Limits at 59 °F (15 °C)

Process Pressure	Flow Rate Limits	Minimum and Maximum Air Flow Rates for line sizes 10 in./DN 250 through 12 in./DN 300							
		10 in./DN 250				12 in./DN 300			
		Rosemount 8800D		Rosemount 8800DR		Rosemount 8800D		Rosemount 8800DR	
		ACFM	ACMH	ACFM	ACMH	ACFM	ACMH	ACFM	ACMH
0 psig (0 bar G)	max	8214	13956	5211	8853	11781	20016	8214	13956
	min	712.9	1211	452	768	1022	1736	712.9	1211
50 psig (3,45 bar G)	max	8214	13956	5211	8853	11781	20016	8214	13956
	min	339.5	577	215	365	486.9	827	339.5	577
100 psig (6,89 bar G)	max	8214	13956	5211	8853	11781	20016	8214	13956
	min	254.7	433	162	276	365.4	621	254.7	433
150 psig (10,3 bar G)	max	8214	13956	5211	8853	11781	20016	8214	13956
	min	213.6	363	135	229	306.3	520	213.6	363
200 psig (13,8 bar G)	max	8214	13956	5211	8853	11781	20016	8214	13956
	min	213.6	363	135	229	306.3	520	213.6	363
300 psig (20,7 bar G)	max	7664	13021	4862	8260	10992	18675	7664	13021
	min	213.6	363	135	229	306.3	520	213.6	363
400 psig (27,6 bar G)	max	6664	11322	4228	7183	9559	16241	6664	11322
	min	213.6	363	136	229	306.3	520	213.6	363
500 psig (34,5 bar G)	max	5972	10146	3789	6437	8565	14552	5972	10146
	min	213.6	363	136	229	306.3	520	213.6	363

## NOTES

The Rosemount 8800D measures the volumetric flow under operating conditions (i.e. the actual volume at the operating pressure and temperature—acfm or acmh), as shown above. However, gas volumes are strongly dependent on pressure and temperature.

Therefore, gas quantities are typically stated in standard or normal conditions (e.g. SCFM or NCMH). (Standard conditions are typically 59 °F and 14.7 psia. Normal conditions are typically 0 °C and 1 bar abs.)

The flow rate limits in standard conditions are found using the equations below:

Standard Flow Rate = Actual Flow Rate X Density Ratio

Density Ratio = Density at Actual (Operating) Conditions / Density at Standard Conditions

TABLE 13. Saturated Steam Flow Rate Limits (Assumes Steam Quality is 100%)

Process Pressure	Flow Rate Limits	Minimum and Maximum Saturated Steam Flow Rates for line sizes 1/2 in./DN 15 through 1 in./DN 25							
		1/2 in./DN 15				1 in./DN 25			
		Rosemount 8800D		Rosemount 8800DR		Rosemount 8800D		Rosemount 8800DR	
		lb/hr	kg/hr	lb/hr	kg/hr	lb/hr	kg/hr	lb/hr	kg/hr
15 psig (1,03 bar G)	max	120	54.6	Not Available	Not Available	342	155	120	54.6
	min	12.8	5.81	Available	Available	34.8	15.8	12.8	5.81
25 psig (1,72 bar G)	max	158	71.7	Not Available	Not Available	449	203	158	71.7
	min	14.0	6.35	Available	Available	39.9	18.1	14.0	6.35
50 psig (3,45 bar G)	max	250	113	Not Available	Not Available	711	322	250	113
	min	17.6	8.00	Available	Available	50.1	22.7	17.6	8.00
100 psig (6,89 bar G)	max	429	194	Not Available	Not Available	1221	554	429	194
	min	23.1	10.5	Available	Available	65.7	29.8	23.1	10.5
150 psig (10,3 bar G)	max	606	275	Not Available	Not Available	1724	782	606	275
	min	27.4	12.5	Available	Available	78.1	35.4	27.4	12.5
200 psig (13,8 bar G)	max	782	354	Not Available	Not Available	2225	1009	782	354
	min	31.2	14.1	Available	Available	88.7	40.2	31.2	14.1
300 psig (20,7 bar G)	max	1135	515	Not Available	Not Available	3229	1464	1135	515
	min	37.6	17.0	Available	Available	107	48.5	37.6	17.0
400 psig (27,6 bar G)	max	1492	676	Not Available	Not Available	4244	1925	1492	676
	min	44.1	20.0	Available	Available	125	56.7	44.1	20.0
500 psig (34,5 bar G)	max	1855	841	Not Available	Not Available	5277	2393	1855	841
	min	54.8	24.9	Available	Available	156	70.7	54.8	24.9

TABLE 14. Saturated Steam Flow Rate Limits (Assumes Steam Quality is 100%)

Process Pressure	Flow Rate Limits	Minimum and Maximum Saturated Steam Flow Rates for line sizes 1 1/2 in./DN 40 through 2 in./DN 50							
		1 1/2 in./DN 40				2 in./DN 50			
		Rosemount 8800D		Rosemount 8800DR		Rosemount 8800D		Rosemount 8800DR	
		lb/hr	kg/hr	lb/hr	kg/hr	lb/hr	kg/hr	lb/hr	kg/hr
15 psig (1,03 bar G)	max	917	416	342	155	1511	685	917	416
	min	82.0	37.2	34.8	15.8	135	61.2	82.0	37.2
25 psig (1,72 bar G)	max	1204	546	449	203	1983	899	1204	546
	min	93.9	42.6	39.9	18.1	155	70.2	93.9	42.6
50 psig (3,45 bar G)	max	1904	864	711	322	3138	1423	1904	864
	min	118	53.4	50.1	22.7	195	88.3	118	53.4
100 psig (6,89 bar G)	max	3270	1483	1221	554	5389	2444	3270	1483
	min	155	70.1	65.7	29.8	255	116	155	70.1
150 psig (10,3 bar G)	max	4616	2094	1724	782	7609	3451	4616	2094
	min	184	83.2	78.1	35.4	303	137	184	83.2
200 psig (13,8 bar G)	max	5956	2702	2225	1009	9818	4453	5956	2702
	min	209	94.5	88.7	40.2	344	156	209	94.5
300 psig (20,7 bar G)	max	8644	3921	3229	1464	14248	6463	8644	3921
	min	252	114	107	48.5	415	189	252	114
400 psig (27,6 bar G)	max	11362	5154	4244	1925	18727	8494	11362	5154
	min	295	134	125	56.7	487	221	295	134
500 psig (34,5 bar G)	max	14126	6407	5277	2393	23284	10561	14126	6407
	min	367	167	156	70.7	605	274	367	167

TABLE 15. Saturated Steam Flow Rate Limits (Assumes Steam Quality is 100%)

Process Pressure	Flow Rate Limits	Minimum and Maximum Saturated Steam Flow Rates for line sizes 3 in./DN 80 through 4 in./DN 100							
		3 in./DN 80				4 in./DN 100			
		Rosemount 8800D		Rosemount 8800DR		Rosemount 8800D		Rosemount 8800DR	
		lb/hr	kg/hr	lb/hr	kg/hr	lb/hr	kg/hr	lb/hr	kg/hr
15 psig (1,03 bar G)	max	3330	1510	1511	685	5734	2601	3330	1510
	min	298	135	135	61.2	513	233	298	135
25 psig (1,72 bar G)	max	4370	1982	1983	899	7526	3414	4370	1982
	min	341	155	155	70.2	587	267	341	155
50 psig (3,45 bar G)	max	6914	3136	3138	1423	11905	5400	6914	3136
	min	429	195	195	88.3	739	335	429	195
100 psig (6,89 bar G)	max	11874	5386	5389	2444	20448	9275	11874	5386
	min	562	255	255	116	968	439	562	255
150 psig (10,3 bar G)	max	16763	7603	7609	3451	28866	13093	16763	7603
	min	668	303	303	137	1150	522	668	303
200 psig (13,8 bar G)	max	21630	9811	9818	4453	37247	16895	21630	9811
	min	759	344	344	156	1307	593	759	344
300 psig (20,7 bar G)	max	31389	14237	14248	6463	54052	24517	31389	14237
	min	914	415	415	189	1574	714	914	415
400 psig (27,6 bar G)	max	41258	18714	18727	8494	71047	32226	41258	18714
	min	1073	487	487	221	1847	838	1073	487
500 psig (34,5 bar G)	max	51297	23267	23284	10561	88334	40068	51297	23267
	min	1334	605	605	274	2297	1042	1334	605

TABLE 16. Saturated Steam Flow Rate Limits (Assumes Steam Quality is 100%)

Process Pressure	Flow Rate Limits	Minimum and Maximum Saturated Steam Flow Rates for line sizes 6 in./DN 150 through 8 in./DN 200							
		6 in./DN 150				8 in./DN 200			
		Rosemount 8800D		Rosemount 8800DR		Rosemount 8800D		Rosemount 8800DR	
		lb/hr	kg/hr	lb/hr	kg/hr	lb/hr	kg/hr	lb/hr	kg/hr
15 psig (1,03 bar G)	max	13013	5903	5734	2601	22534	10221	13013	5903
	min	1163	528	513	233	2015	914	1163	528
25 psig (1,72 bar G)	max	17080	7747	7526	3414	29575	13415	17080	7747
	min	1333	605	587	267	2308	1047	1333	605
50 psig (3,45 bar G)	max	27019	12255	11905	5400	46787	21222	27019	12255
	min	1676	760	739	335	2903	1317	1676	760
100 psig (6,89 bar G)	max	46405	21049	20448	9275	80356	36449	46405	21049
	min	2197	996	968	439	3804	1725	2197	996
150 psig (10,3 bar G)	max	65611	29761	28866	13093	113440	51455	65611	29761
	min	2610	1184	1150	522	4520	2050	2610	1184
200 psig (13,8 bar G)	max	84530	38342	37247	16895	146375	66395	84530	38342
	min	2965	1345	1307	593	5134	2329	2965	1345
300 psig (20,7 bar G)	max	122666	55640	54052	24517	212411	96348	122666	55640
	min	3572	1620	1574	714	6185	2805	3572	1620
400 psig (27,6 bar G)	max	161236	73135	71047	32226	279200	126643	161236	73135
	min	4192	1901	1847	838	7259	3293	4192	1901
500 psig (34,5 bar G)	max	200468	90931	88334	40068	347134	157457	200468	90931
	min	5212	2364	2297	1042	9025	4094	5212	2364



# Product Data Sheet

00813-0100-4004, Rev FA

Catalog 2008 - 2009

# Rosemount 8800D

TABLE 17. Saturated Steam Flow Rate Limits (Assumes Steam Quality is 100%)

Process Pressure	Flow Rate Limits	Minimum and Maximum Saturated Steam Flow Rates for line sizes 10 in./DN 250 through 12 in./DN 300							
		10 in./DN 250				12 in./DN 300			
		Rosemount 8800D		Rosemount 8800DR		Rosemount 8800D		Rosemount 8800DR	
		lb/hr	kg/hr	lb/hr	kg/hr	lb/hr	kg/hr	lb/hr	kg/hr
15 psig (1,03 bar G)	max	35519	16111	22534	10221	50994	23130	35519	16111
	min	3175	1440	2015	914	4554	2066	3175	1440
25 psig (1,72 bar G)	max	46618	21146	29575	13415	66862	30328	46618	21146
	min	4570	2073	2308	1047	5218	2367	4570	2073
50 psig (3,45 bar G)	max	73748	33452	46787	21222	105774	47978	73748	33452
	min	4575	2075	2903	1317	6562	2976	4575	2075
100 psig (6,89 bar G)	max	126660	57452	80356	36449	181663	82401	126660	57452
	min	5996	2720	3804	1725	8600	3901	5996	2720
150 psig (10,3 bar G)	max	178808	81106	113440	51455	256457	116327	178808	81106
	min	7125	3232	4520	2050	10218	4635	7125	3232
200 psig (13,8 bar G)	max	230722	104654	146375	66395	330915	150101	230722	104654
	min	8092	3670	5134	2329	11607	5265	8092	3670
300 psig (20,7 bar G)	max	334810	151867	212411	96348	480203	217816	334810	151867
	min	9749	4422	6185	2805	13983	6343	9749	4422
400 psig (27,6 bar G)	max	440085	199619	279200	126643	631195	286305	440085	199619
	min	11442	5190	7259	3293	16411	7444	11442	5190
500 psig (34,5 bar G)	max	547165	248190	347134	157457	784775	355968	547165	248190
	min	14226	6453	9025	4094	20404	9255	14226	6453

## PERFORMANCE SPECIFICATIONS

The following performance specifications are for all Rosemount models except where noted. Digital performance specifications applicable to both Digital HART and FOUNDATION fieldbus output.

### Flow Accuracy

Includes linearity, hysteresis, and repeatability.

#### Liquids - for Reynolds Numbers over 20000

##### Digital and Pulse Output

±0.65% of rate

Note: The accuracy for the 8800DR, line sizes 6 to 12 in. (150 to 300mm), is ±1.0% of rate.

##### Analog Output

Same as pulse output plus an additional 0.025% of span

#### Gas and Steam - for Reynolds Numbers over 15,000

##### Digital and Pulse Output

±1.35% of rate

Note: The accuracy for the 8800DR, line sizes 6 to 12 in. (150 to 300mm), is ±1.50% of rate.

##### Analog Output

Same as pulse output plus an additional 0.025% of span

#### Accuracy limitations for gas and steam:

For 1/2 and 1 in. (DN 15 and DN 25): max velocity of 220 ft/s (67.06 m/s)

For 1/2 to 8 in. (DN 15 to DN 200) Dual-style meters: max velocity of 100 ft/s (30.5 m/s)

#### NOTE

For 1/2 in. through 4 in. (15 mm through 100 mm) line sizes, as the meter Reynolds number decreases below the stated limit to 10000, the positive limit of the accuracy error band will increase to 2.1% for the pulse output. Example: +2.1% to -0.65% for liquids.

#### Process Temperature Accuracy

2.2 °F (1.2 °C) or 0.4% of reading (in °C), whichever is greater.

#### NOTE

For remote mount installations, add ±0.018 °F/ft. (±0.03 °C/m) of uncertainty to the temperature measurement.

### Mass Flow Accuracy for Temperature Compensated Mass Flow

#### Digital and Pulse Output

± 2.0% of rate (Nominal)

Nominal conditions include temperature variation in saturation and superheat at 150 psig (10 bar-g) and above.

For pressure below 150 psig (10 bar-g), add 0.08% of uncertainty for every 15 psi (1 bar) below 150 psig (10 bar-g).

#### Analog Output

Same as pulse output plus an additional 0.025% of span

#### Repeatability

± 0.1% of actual flow rate

#### Stability

± 0.1% of rate over one year

#### Process Temperature Effect

Automatic K-factor correction with user-entered process temperature.

Table 18 indicates the percent change in K-factor per 100 °F (55.5 °C) in process temperature from reference temperature of 77 °F (25 °C).

TABLE 18. Process Temperature Effect

Material	Percent Change in K-Factor per 100 °F (55.5 °C)
316L @ < 77 °F (25 °C)	+ 0.23
316L @ > 77 °F (25 °C)	- 0.27
Nickel Alloy C < 77 °F (25 °C)	+ 0.22
Nickel Alloy C > 77 °F (25 °C)	- 0.22

#### Ambient Temperature Effect

##### Digital and Pulse Outputs

No effect

##### Analog Output

±0.1% of span from -58 to 185 °F (-50 to 85 °C)

## Product Data Sheet

00813-0100-4004, Rev FA  
Catalog 2008 - 2009

# Rosemount 8800D

---

### Vibration Effect

An output with no process flow may be detected if sufficiently high vibration is present.

The meter design will minimize this effect, and the factory settings for signal processing are selected to eliminate these errors for most applications.

If an output error at zero flow is still detected, it can be eliminated by adjusting the low flow cutoff, trigger level, or low-pass filter.

As the process begins to flow through the meter, most vibration effects are quickly overcome by the flow signal. At or near the minimum liquid flow rate in a normal pipe mounted installation, the maximum vibration should be 0.087 in. (2,21 mm) double amplitude displacement or 1 g acceleration, whichever is smaller. At or near the minimum gas flow rate in a normal pipe mounted installation, the maximum vibration should be 0.043 in. (1,09 mm) double amplitude displacement or 1/2 g acceleration, whichever is smaller.

### Mounting Position Effect

Meter will meet accuracy specifications when mounted in horizontal, vertical, or inclined pipelines. Best practice for mounting in a horizontal pipe is to orient the shedder bar in the horizontal plane. This will prevent solids in liquid applications and liquid in gas/steam applications from disrupting the shedding frequency.

### EMI/RFI Effect

Meets EMC requirements to EU Directive 2004/108/EC.

#### HART Analog

Output error less than  $\pm 0.025\%$  of span with twisted pair from 80-1000 MHz for radiated field strength of 10 V/m. Tested per EN61326.

#### Foundation fieldbus and Digital HART

No affect on the values that are being given if using HART digital signal or FOUNDATION fieldbus. Tested per EN61326.

### Magnetic-Field Interference

#### HART Analog

Output error less than  $\pm 0.025\%$  of span at 30 A/m (rms); meets IEC 60770-1984, Section 6.2.9. Tested per EN61326.

### Foundation fieldbus

No effect on digital output accuracy at 30 A/m (rms). Tested per EN 61326.

### Series Mode Noise Rejection

#### HART Analog

Output error less than  $\pm 0.025\%$  of span at 1 V rms, 60 Hz; meets IEC 60770-1984, Section 6.2.4.2.

#### Foundation fieldbus

No effect on digital output accuracy at 1 V rms 60 Hz. Meets IEC 60770-1984, Section 6.2.4.2

### Common Mode Noise Rejection

#### HART Analog

Output error less than  $\pm 0.025\%$  of span at 30 V rms, 60 Hz; meets IEC 60770-1984, Section 6.2.4.1.

#### Foundation fieldbus

No effect on digital output accuracy at 250 V rms, 60 Hz. According to FF-830-PS-2.0 test case 8.2.

### Power Supply Effect

#### HART Analog

Less than 0.005% of span per volt

#### Foundation fieldbus

No effect on accuracy.

### PHYSICAL SPECIFICATIONS

#### NACE Compliance

Materials of Construction meet NACE material recommendations per MR0175/ISO15156 for use in H<sub>2</sub>S containing environments in oil field production. Materials of construction also meet NACE recommendations per MR0103-2003 for corrosive petroleum refining environments. MR0103 compliance requires Q25 option in model code.

#### Electrical Connections

1/2 –14 NPT, PG 13.5, or M20 × 1.5 conduit threads; screw terminals provided for 4–20 mA and pulse output connections; communicator connections permanently fixed to terminal block.

#### Non-Wetted Materials

##### Housing

Low-copper aluminum (FM Type 4X, CSA Type 4X, IP66)

##### Paint

Polyurethane

##### Cover O-rings

Buna-N

##### Flanges

316/316L lap joint

##### Temperature Sensor (MTA Option)

Type-N Special Limits Thermocouple

#### Process-Wetted Materials

##### Meter Body

316L wrought stainless and CF-3M cast stainless or N06022 wrought Nickel Alloy and CW2M cast Nickel Alloy. Other material grades available. Consult factory for other materials of construction.

##### Flanges

316/316L stainless steel

Nickel Alloy N06022 Weld Neck

##### Collars

Nickel Alloy N06022

Surface Finish of Flanges and Collars  
Standard: 125 to 250 μ inches  
(3.1 to 6.3 μ meters) Ra roughness

Smooth: 63 to 125 μ inches  
(1.6 to 3.1 μ meters) Ra roughness

#### Process Connections

Mounts between the following flange configurations:

ASME B16.5 (ANSI): Class 150, 300, 600, 900, 1500

DIN: PN 10, 16, 25, 40, 64, 100, 160

JIS: 10K, 20K, and 40K

Weld-end: Schedule 10, Schedule 40, Schedule 80, Schedule 160

#### Mounting

##### Integral (Standard)

Electronics are mounted on meter body.

##### Remote (Optional)

Electronics may be mounted remote from the meter body. Interconnecting coaxial cable available in nonadjustable 10, 20, and 30 ft (3,0, 6,1, and 9,1 m) lengths. Consult factory for non-standard lengths up to 75 ft (22,9 m). Remote mounting hardware includes a polyurethane painted, carbon steel pipe mount bracket with one carbon steel u-bolt.

##### Temperature Limitations for Integral Mounting

The maximum process temperature for integral mount electronics is dependent on the ambient temperature where the meter is installed. The electronics must not exceed 185°F (85°C). The following is for reference, please note that the pipe was insulated with 3 inches of ceramic fiber insulator.

FIGURE 1. Rosemount 8800 Vortex Flowmeter  
Ambient/process temperature limits

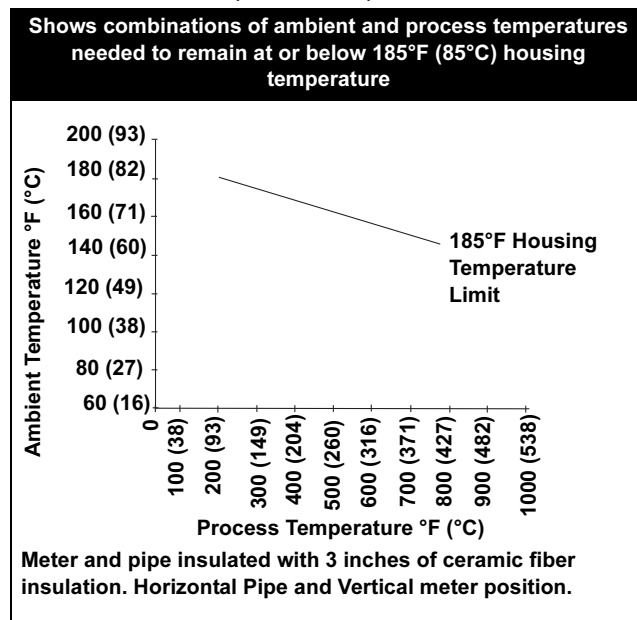

## Product Data Sheet

00813-0100-4004, Rev FA  
Catalog 2008 - 2009

Rosemount 8800D

---

### Pipe Length Requirements

The vortex meter may be installed with a minimum of ten straight pipe diameters (D) upstream and five straight pipe diameters (D) downstream by following the K-factor corrections as described in the Technical Data Sheet (00816-0100-3250) on Installation Effects. No K-factor correction is required if 35 diameters upstream (35D) and 10 diameters downstream (10D) are available.

### Tagging

The flowmeter will be tagged at no charge, according to customer requirements. All tags are stainless steel. The standard tag is permanently attached to the flowmeter. Character height is 1/16 in. (1,6 mm). A wired-on tag is available on request.

### Flow Calibration Information

Flowmeter calibration and configuration information is provided with every flowmeter. For a certified copy of flow calibration data, Option Q4 must be ordered in the model number.

## Product Certifications

### Approved Manufacturing Locations

Rosemount Inc. — Eden Prairie, Minnesota, USA  
Emerson Process Management BV - Ede, The Netherlands

### EUROPEAN DIRECTIVE INFORMATION

The CE Declaration of Conformity for all applicable European directives for this product can be found on our website at [www.rosemount.com](http://www.rosemount.com). A hard copy may be obtained by contacting our local sales office.

### ATEX Directive

Rosemount Inc. complies with the ATEX Directive.

#### Flameproof enclosure EEx d protection type in accordance with EN50018



- Transmitters with Flameproof enclosure type protection shall only be opened when power is removed.
- Closing of entries in the device must be carried out using the appropriate EEx d metal cable gland or metal blanking plug.
- Do not exceed the energy level, which is stated on the approval label.

#### Type n protection type in accordance with EN60079-15



Closing of entries in the device must be carried out using the appropriate EExe or EExn metal cable gland and metal blanking plug or any appropriate ATEX approved cable gland and blanking plug with IP66 rating certified by an EU approved certification body.

### EUROPEAN PRESSURE EQUIPMENT DIRECTIVE (PED)

#### Rosemount 8800 Vortex Flowmeter Line Size 40 mm to 300 mm

Certificate Number PED-H-100

CE 0575

Module H Conformity Assessment

Mandatory CE-marking for flowmeters in accordance with Article 15 of the PED can be found on the flowtube body.

Flowmeter categories I – IV, use module H for conformity assessment procedures.

#### Rosemount 8800 Vortex Flowmeter Line Size 15 mm and 25 mm

Sound Engineering Practice

Flowmeters that are SEP or Category I with Explosion-Proof protection are outside the scope of PED and cannot be marked for compliance with PED.

**HAZARDOUS LOCATION  
CERTIFICATIONS**

**Rosemount 8800D with HART Protocol**

**North American Certifications**

**Factory Mutual (FM)**

- E5** Explosion-Proof for Class I, Division 1, Groups B, C, and D; Dust-ignition proof for Class II/III, Division 1, Groups E, F, and G; Temp Code T6 ( $-50^{\circ}\text{C} \leq T_a \leq 70^{\circ}\text{C}$ ) Conduit Seal not required Enclosure Type 4X.
- I5** Intrinsically safe for use in Class I, Division 1, Groups A, B, C, and D; Class I, Zone 0, AEx ia IIC T4 ( $-50^{\circ}\text{C} \leq T_a \leq 70^{\circ}\text{C}$ ); Class II/III, Division 1, Groups E, F, and G locations when connected in accordance with Rosemount drawings 08800-0116; Non-incendive for Class I, Division 2, Groups A, B, C, and D and Suitable for Class I, Division 2, Groups A, B, C, and D, with non-incendive field wiring (NIFW) when installed in accordance with Rosemount drawing 08800-0116; Temperature code T4 ( $-50^{\circ}\text{C} \leq T_a \leq 70^{\circ}\text{C}$ ) Enclosure Type 4X.
- K5** E5 and I5 Combination

**Canadian Standards Association (CSA)**

- E6** Explosion-Proof for Class I, Division 1, Groups B, C, and D; Dust-ignition proof for Class II and Class III, Division 1, Groups E, F, and G; Temp Code T5 ( $T_a = 70^{\circ}\text{C}$ ) Class I Zone1; Ex d (ia) T6 ( $-50^{\circ}\text{C} \leq T_a \leq 70^{\circ}\text{C}$ ) Suitable for Class I, Division 2, Groups A, B, C, and D; Temp Code T3C. Factory sealed. Enclosure Type 4X.
- I6** Intrinsically safe for Class I, Division 1, Groups A, B, C, and D; When connected in accordance with Rosemount drawing 08800-0112; Temperature code T3C Enclosure Type 4X.
- K6** E6 and I6 Combination

**European Certifications**

**ATEX Intrinsic Safety**

- I1** Certification No. Baseefa05ATEX0084X  
ATEX Marking  II 1 G  
EEx ia IIC T5 ( $-60^{\circ}\text{C} \leq T_a \leq 40^{\circ}\text{C}$ )  
EEx ia IIC T4 ( $-60^{\circ}\text{C} \leq T_a \leq 70^{\circ}\text{C}$ )  
Input Parameters:  
 $U_i = 30$  VDC  
 $I_i^{(1)} = 185$  mA  
 $P_i^{(1)} = 1.0$  W  
 $C_i = 0$   $\mu$ F  
 $L_i = 0.97$  mH  
**CE** 0575

**SPECIAL CONDITIONS**

When fitted with 90V transient suppressors (T1 Option), the equipment is not capable of passing the 500V isolation test. This must be taken into account upon installation.



**ATEX Type N Certification**

- N1** Certification No. Baseefa05ATEX0085X  
ATEX Marking  II 3 G  
EEx nAnL II T5 ( $-40^{\circ}\text{C} \leq T_a \leq 70^{\circ}\text{C}$ )  
Input Parameters:  
 $U_i = 42$  V dc Max  
 $C_i = 0$   $\mu$ F  
 $L_i = 0.97$  mH

**SPECIAL CONDITIONS**

When fitted with 90V transient suppressors (T1 Option), the equipment is not capable of passing the 500V isolation test. This must be taken into account upon installation.

**ATEX Flameproof Certification**

- E1** Certification No. KEMA99ATEX3852X  
ATEX Marking Remote Mount:  
Transmitter:  II 2(1) G  
EEx d [ia] IIC T6 ( $-50^{\circ}\text{C} \leq T_a \leq 70^{\circ}\text{C}$ )  
Meter Body:  II 1 G  
EEx ia IIC T6 ( $-50^{\circ}\text{C} \leq T_a \leq 70^{\circ}\text{C}$ )  
ATEX Marking Integral Mount:  II 1/2 G  
EEx d [ia] IIC T6 ( $-50^{\circ}\text{C} \leq T_a \leq 70^{\circ}\text{C}$ )  
**CE** 0575  
 $V = 42$  Vdc Max  
 $U_m = 250$  V

(1) Total for transmitter

---

### SPECIAL CONDITIONS

When the equipment is installed, precautions must be taken to ensure, taking into account the effect of the fluid temperature, that the ambient temperature of the electrical parts of the equipment is comprised between  $-50^{\circ}\text{C}$  and  $70^{\circ}\text{C}$ .

The remote mounted sensor may only be connected to the transmitter with the associated cable, supplied by the manufacturer.

---

### ATEX Dust Certification

- ND** Certification No. Baseefa05ATEX0086  
ATEX Marking  II 1 D T90°C ( $-20^{\circ}\text{C} \leq T_a \leq 70^{\circ}\text{C}$ )  
 $U_i = 42\text{ V dc}$   
**CE** 0575
- K1** E1, I1, N1 and ND Combination

---

### International IECEx Certifications

#### Intrinsic Safety

- I7** Certification No. IECEx BAS05.0028X  
Ex ia IIC T5 ( $-60^{\circ}\text{C} \leq T_a \leq 40^{\circ}\text{C}$ )  
Ex ia IIC T4 ( $-60^{\circ}\text{C} \leq T_a \leq 70^{\circ}\text{C}$ )  
Input Parameters:  
 $U_i = 30\text{ VDC}$   
 $I_i = 185\text{ mA}$   
 $P_i = 1.0\text{ W}$   
 $C_i = 0\text{ }\mu\text{F}$   
 $L_i = 0.97\text{ mH}$
- 

### SPECIAL CONDITIONS

When fitted with 90V transient suppressors (T1 Option), the equipment is not capable of passing the 500V isolation test. This must be taken into account upon installation.

---

#### Type N Certification

- N7** Certification No. IECEx BAS05.0029X  
Ex nC IIC T5 ( $-40^{\circ}\text{C} \leq T_a \leq 70^{\circ}\text{C}$ )  
 $U_i = 42\text{ V dc}$
- 

### SPECIAL CONDITIONS

When fitted with 90V transient suppressors (T1 Option), the equipment is not capable of passing the 500V isolation test. This must be taken into account upon installation.

---

#### Flameproof Certification

- E7** Certification No. IECEx KEM05.0017X  
Marking Remote Mount:  
Transmitter: Ex d [ia] IIC T6 ( $-50^{\circ}\text{C} \leq T_a \leq 70^{\circ}\text{C}$ )  
Meter Body: Ex ia IIC T6 ( $-50^{\circ}\text{C} \leq T_a \leq 70^{\circ}\text{C}$ )  
Marking Integral Mount: Ex d [ia] IIC T6  
( $-50^{\circ}\text{C} \leq T_a \leq 70^{\circ}\text{C}$ )  
 $V = 42\text{ Vdc Max}$   
 $U_m = 250\text{V}$
- 

### SPECIAL CONDITIONS

When the equipment is installed, particular precautions must be taken to ensure, taking into account the effect of the process fluid temperature, that the ambient temperature of the electrical parts of the equipment is comprised between  $-50^{\circ}\text{C}$  and  $70^{\circ}\text{C}$ .

The remote mounted sensor shall only be connected to the transmitter with the associated cable, supplied by the manufacturer.

---

- K7** E7, I7, and N7 Combination



## Product Data Sheet

00813-0100-4004, Rev FA  
Catalog 2008 - 2009

Rosemount 8800D

---

### Chinese Certifications (NEPSI)

#### Flameproof Certification

**E3** Certification No. GYJ071327X  
Ex dia IIC T6 (-50°C to 70°C)

#### Intrinsic Safety

**I3** Certification No. GYJ071171X  
Ex ia IIC T4/T5  
T4: (-60°C to 70°C)  
T5: (-60°C to 40°C)  
Input Parameters:  
U<sub>i</sub> = 30 VDC  
I<sub>i</sub> = 185 mA  
P<sub>i</sub> = 1.0 W  
C<sub>i</sub> = 0 µF  
L<sub>i</sub> = 0.97 mH

#### Type N Certification

**N3** Certification No. GYJ071193X  
Ex nAnL IIC T5 (-40°C to 70°C)  
42 VDC Max  
**K3** E3, I3, and N3 Combination

### Japanese Certifications (TIIS)

#### Flameproof Certification

**E4** Transmitter - Ex d [ia] T6  
Remote Sensor - Ex ia IIC T6  
Certificate Description  
TC17816 8800D with display, without MTA option  
TC17817 8800D without display, without MTA option  
TC17905 8800D with display, with MTA option  
TC17906 8800D without display, with MTA option

### Combination Certifications

**KB** E5, I5, E6, and I6 Combination

### Rosemount 8800D With FOUNDATION Fieldbus Protocol

#### North American Certifications

##### Factory Mutual (FM) Approvals

- E5** Explosion-Proof for Class I, Division 1, Groups B, C, and D.  
Dust-Ignition proof for Class II/III, Division 1, Groups E, F, and G.  
Temperature Code T6 (-50°C ≤ Ta ≤ 70°C)  
Conduit seal not required.  
Enclosure Type 4X
- I5** Intrinsically safe for use in Class I, Division 1, Groups A, B, C, and D;  
Class I, Zone 0, AEx ia IIC T4 (-50°C ≤ Ta ≤ 40°C);  
Class II/III, Division 1, Groups E, F, and G locations when connected in accordance with Rosemount drawings 08800-0116;  
Non-incendive for Class I, Division 2, Groups A, B, C, and D and Suitable for Class I, Division 2, Groups A, B, C, and D, with non-incendive field wiring (NIFW) when installed in accordance with Rosemount drawing 08800-0116;  
Temperature code T4 (-50°C ≤ Ta ≤ 40°C)  
Enclosure Type 4X.
- IE** FISCO for Class I, Division 1, Groups A, B, C, and D.  
Class II/III, Division 1, Groups E, F, and G.  
Temp. Code: T4 (-50°C ≤ Ta ≤ 40°C)  
when installed per Rosemount control drawing 08800-0116.
- K5** E5 and I5 combination

##### Canadian Standards Association (CSA) Approvals

- E6** Explosion-Proof for Class I, Division 1, Groups B, C, and D;  
Dust-ignition proof for Class II and Class III, Division 1, Groups E, F, and G; Temp Code T5 (TA = 70°C)  
Class I Zone1; Ex d (ia) T6 (-50°C ≤ Ta ≤ 70°C)  
Suitable for Class I, Division 2, Groups A, B, C, and D;  
Temp Code T3C.  
Factory sealed.  
Enclosure Type 4X.
- I6** Intrinsically Safe for Class I, Division 1,  
Groups A, B, C, and D;  
When connected in accordance with Rosemount drawing 08800-0112;  
Temperature Code T3C.  
Enclosure Type 4X
- IF** FISCO for Class I, Division 1, Groups A, B, C, and D;  
Temperature Code: T3C.  
When installed per Rosemount drawing 08800-0112  
Enclosure Type 4X
- K6** E6 and I6 combination.

#### European Certifications

##### ATEX Intrinsic Safety Certification

- I1** Certification No. Baseefa05ATEX0084X  
ATEX Marking  II 1 G  
EEx ia IIC T4 (-60°C ≤ Ta ≤ 60°C)  
**CE** 0575  
Input Parameters:  
U<sub>i</sub> = 30 VDC  
I<sub>i</sub> = 300 mA  
P<sub>i</sub> = 1.3 W  
C<sub>i</sub> = 0 μF  
L<sub>i</sub> = 20 μH

##### SPECIAL CONDITIONS FOR SAFE USE (X)

When fitted with 90V transient suppressors (T1 Option), the equipment is not capable of passing the 500V isolation test. This must be taken into account upon installation.

##### ATEX FISCO

- IA** Certification No. Baseefa05ATEX0084X  
ATEX Marking  II 1 G  
EEx ia IIC T4 (-60°C ≤ Ta ≤ 60°C)  
**CE** 0575  
Input Parameters:  
U<sub>i</sub> = 17.5 VDC  
I<sub>i</sub> = 380 mA  
P<sub>i</sub> = 5.32 W  
C<sub>i</sub> = 0 μF  
L<sub>i</sub> < 10 μH

##### SPECIAL CONDITIONS FOR SAFE USE (X)

When fitted with 90V transient suppressors (T1 Option), the equipment is not capable of passing the 500V isolation test. This must be taken into account upon installation.

##### ATEX Type N Certification

- N1** Certification No. Baseefa05ATEX0085X  
ATEX Marking  II 3 G  
EEx nAnL IIC T5 (-40°C ≤ Ta ≤ 70°C)  
Input Parameters:  
U<sub>i</sub> = 42 VDC MAX  
C<sub>i</sub> = 0 μF  
L<sub>i</sub> = 20 μH

##### SPECIAL CONDITIONS FOR SAFE USE (X)



When fitted with 90V transient suppressors (T1 Option), the equipment is not capable of passing the 500V isolation test. This must be taken into account upon installation.

## Product Data Sheet

00813-0100-4004, Rev FA  
Catalog 2008 - 2009

# Rosemount 8800D

### ATEX Flame-Proof Certifications

- E1** Certification No. KEMA 99ATEX3852X  
ATEX Marking Remote Mount:  
Transmitter:  II 2(1) G  
EEx d [ia] IIC T6 (-50°C ≤ Ta ≤ 70°C)  
Meter Body:  II 1 G  
EEx ia IIC T6 (-50°C ≤ Ta ≤ 70°C)  
ATEX Marking Integral Mount:  II 1/2 G  
EEx d [ia] IIC T6 (-50°C ≤ Ta ≤ 70°C)  
**CE** 0575  
V = 42 Vdc Max  
Um = 250V

### SPECIAL CONDITIONS

When the equipment is installed, particular precautions must be taken to ensure, taking into account the effect of the process fluid temperature, that the ambient temperature of the electrical parts of the equipment is comprised between -50°C and 70°C.

The remote mounted sensor shall only be connected to the transmitter with the associated cable, supplied by the manufacturer.

### ATEX Dust Certification

- ND** Certification No. Baseefa05ATEX0086  
ATEX Marking  II 1 D T90°C (-20°C ≤ Ta ≤ 70°C)  
Ui = 42 VDC  
**CE** 0575
- K1** E1, I1, N1 and ND Combination

### International IECEx Certifications

#### Intrinsic Safety

- I7** Certification No. IECEx BAS 05.0028X  
Ex ia IIC T4 (-60°C ≤ Ta ≤ 60°C)  
Input Parameters:  
Ui = 30 VDC  
Ii = 300 mA  
Pi = 1.3 W  
Ci = 0 μF  
Li = 20 μH

### SPECIAL CONDITIONS

When fitted with 90V transient suppressors (T1 Option), the equipment is not capable of passing the 500V isolation test. This must be taken into account upon installation.

#### FISCO

- IG** Certification No. IECEx BAS 05.0028X  
Ex ia IIC T4 (-60°C ≤ Ta ≤ 60°C)  
Input Parameters:  
Ui = 17.5 VDC  
Ii = 380 mA  
Pi = 5.32 W  
Ci = 0 μF  
Li < 10 μH

#### Type N Certification

- N7** Certification No. IECEx BAS 05.0029X  
Ex nC IIC T5 (-40°C ≤ Ta ≤ 70°C)  
Ui = 42 V dc

#### Flameproof Certification

- E7** Certification No. IECEx KEM 05.0017X  
Marking Remote Mount:  
Transmitter: Ex d [ia] IIC T6 (-50°C ≤ Ta ≤ 70°C)  
Meter Body: Ex ia IIC T6 (-50°C ≤ Ta ≤ 70°C)  
Marking Integral Mount: Ex d [ia] IIC T6  
(-50°C ≤ Ta ≤ 70°C)  
V = 42 Vdc Max  
Um = 250V

### SPECIAL CONDITIONS

When the equipment is installed, particular precautions must be taken to ensure, taking into account the effect of the process fluid temperature, that the ambient temperature of the electrical parts of the equipment is comprised between -50°C and 70°C.

The remote mounted sensor shall only be connected to the transmitter with the associated cable, supplied by the manufacturer.

- K7** E7, I7, and N7 Combination

# Rosemount 8800D

---

## Chinese Certifications (NEPSI)

### Flameproof Certification

**E3** Certification No. GYJ071327X  
Ex dia T6 (-50°C to 70°C)

### Intrinsic Safety

**I3** Certification No. GYJ071171X  
Ex ia IIC T6 (-60°C to 60°C)  
Input Parameters:  
U<sub>i</sub> = 30 VDC  
I<sub>i</sub> = 300 mA  
P<sub>i</sub> = 1.3 W  
C<sub>i</sub> = 0 µF  
L<sub>i</sub> = 20 µH

### FISCO/FNICO

#### **IH For FISCO:**

Certification No. GYJ071171X  
Ex ia IIC T4 (-60°C to 60°C)

Input Parameters:  
U<sub>i</sub> = 17.5 VDC  
I<sub>i</sub> = 380 mA  
P<sub>i</sub> = 5.32 W  
C<sub>i</sub> = 0 µF  
L<sub>i</sub> < 10 µH

#### **For FNICO:**

Certification No. GYJ071193X  
Ex nAnL IIC T5 (-40°C to 70°C)  
17.5 VDC Max

### Type N Certification

**N3** Certification No. GYJ071193X  
Ex nAnL IIC T5 (-40°C to 70°C)

32 VDC Max

**K3** E3, I3, and N3 Combination

## Japanese Certifications (TIIS)

### Flameproof Certification

#### **E4 TIIS Flameproof**

Transmitter - Ex d [ia] T6

Remote Sensor - Ex ia IIC T6

Certificate Description

TC17816 8800D with display, without MTA option

TC17817 8800D without display, without MTA option

### Combination Certifications

**KB** E5, I5, E6, and I6 Combination

## Dimensional Drawings

FIGURE 2. Flanged-Style Flowmeter Dimensional Drawings (<sup>1</sup>/<sub>2</sub>-through 12 in./15 through 300 mm Line Sizes)

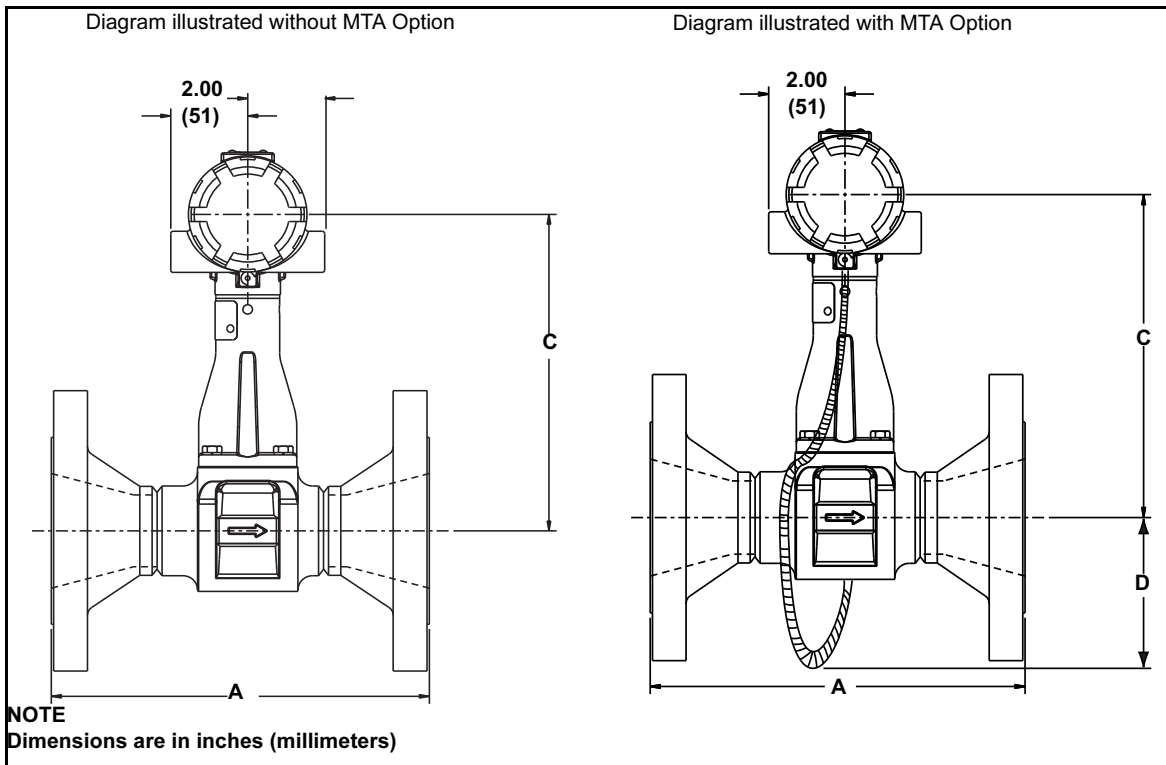
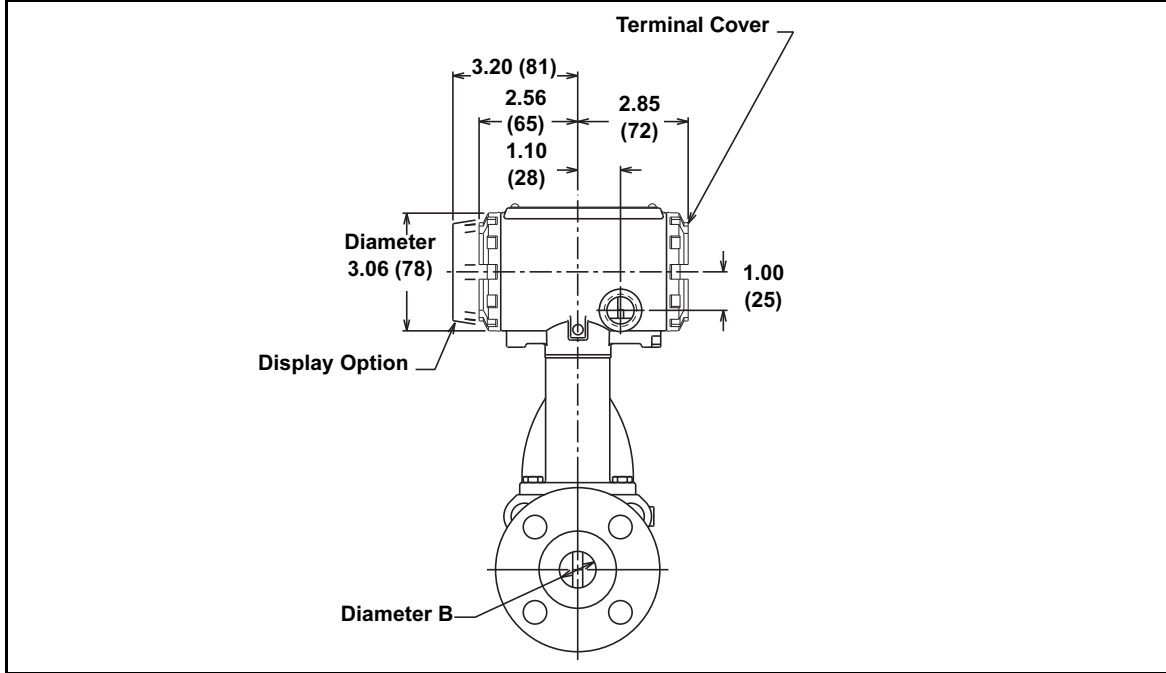

# Rosemount 8800D

## Product Data Sheet

00813-0100-4004, Rev FA

Catalog 2008 - 2009

TABLE 19. Flanged-Style Flowmeter ( $1/2$ -through 2in./15 through 50 mm Line Sizes)

Nominal Size in. (mm)	Flange Rating	Face-to-face A in. (mm) <sup>(1)</sup>	A-ANSI RTJ in. (mm)	Diameter B in. (mm) <sup>(2)</sup>	C in. (mm) <sup>(3)</sup>	D in. (mm)	Weight <sup>(4)</sup> lb (kg)
1/2 (15)	Class 150	6.9 (175)	–	0.54 (13,7)	7.6 (193)		9.1 (4,1)
	Class 300	7.2 (183)	7.7 (196)	0.54 (13,7)	7.6 (193)		10.4 (4,7)
	Class 600	7.7 (196)	7.7 (196)	0.54 (13,7)	7.6 (193)		10.8 (4,9)
	Class 900	8.4 (213)	8.4 (213)	0.54 (13,7)	7.6 (193)		15.3 (6,9)
	PN 16/40	6.1 (155)	–	0.54 (13,7)	7.6 (193)		10.4 (4,7)
	PN 100	6.6 (168)	–	0.54 (13,7)	7.6 (193)		12.3 (5,6)
	JIS 10K/20K JIS 40K	6.3 (160) 7.3 (185)	– –	0.54 (13,7) 0.54 (13,7)	7.6 (193) 7.6 (193)		10.1 (4,5) 13.5 (6,1)
1 (25)	Class 150	7.5 (191)	8.0 (203)	0.95 (24,1)	7.7 (196)		12.3 (5,6)
	Class 300	8.0 (203)	8.5 (216)	0.95 (24,1)	7.7 (196)		15.0 (6,8)
	Class 600	8.5 (216)	8.5 (216)	0.95 (24,1)	7.7 (196)		15.8 (7,2)
	Class 900	9.4 (239)	9.4 (239)	0.95 (24,1)	7.7 (196)		24.3 (11,0)
	Class 1500	9.4 (239)	9.4 (239)	0.95 (24,1)	7.7 (196)		24.3 (11,0)
	PN 16/40	6.3 (160)	–	0.95 (24,1)	7.7 (196)		13.5 (6,1)
	PN 100 PN 160	7.7 (195) 7.7 (195)	– –	0.95 (24,1) 0.95 (24,1)	7.7 (196) 7.7 (196)		19.5 (8,8) 19.5 (8,8)
JIS 10K/20K JIS 40K	6.5 (165) 7.9 (200)	– –	0.95 (24,1) 0.95 (24,1)	7.7 (196) 7.7 (196)		13.7 (6,2) 17.4 (7,9)	
1 1/2 (40)	Class 150	8.2 (208)	8.7 (221)	1.49 (37,8)	8.1 (206)		17.6 (8,0)
	Class 300	8.7 (221)	9.2 (234)	1.49 (37,8)	8.1 (206)		23.0 (10,4)
	Class 600	9.4 (239)	9.4 (239)	1.49 (37,8)	8.1 (206)		25.3 (11,5)
	Class 900	10.4 (264)	10.4 (264)	1.49 (37,8)	8.1 (206)		36.3 (16,5)
	Class 1500	10.4 (264)	10.4 (264)	1.49 (37,8)	8.1 (206)		36.6 (16,6)
	PN 16/40	6.9 (175)	–	1.49 (37,8)	8.1 (206)		19.3 (8,8)
	PN 100 PN 160	8.2 (208) 8.4 (213)	– –	1.49 (37,8) 1.49 (37,8)	8.1 (206) 8.1 (206)		27.9 (12,7) 29.3 (13,3)
JIS 10K/20K JIS 40K	7.3 (185) 8.5 (215)	– –	1.49 (37,8) 1.49 (37,8)	8.1 (206) 8.1 (206)		18.6 (8,4) 25.6 (11,6)	
2 (50)	Class 150	9.3 (236)	9.8 (249)	1.92 (48,8)	8.5 (216)	4.7 (119)	22.0 (10,0)
	Class 300	9.8 (249)	10.4 (264)	1.92 (48,8)	8.5 (216)	4.7 (119)	26.0 (11,8)
	Class 600	10.5 (267)	10.7 (271)	1.92 (48,8)	8.5 (216)	4.7 (119)	29.6 (13,4)
	Class 900	12.8 (325)	12.9 (328)	1.92 (48,8)	8.5 (216)	4.7 (119)	59.4 (26,9)
	Class 1500	12.8 (325)	12.9 (328)	1.79 (45,5)	8.5 (216)	–	59.4 (26,9)
	PN 16/40	8.0 (203)	–	1.92 (48,8)	8.5 (216)	4.7 (119)	23.0 (10,4)
	PN 64	9.2 (234)	–	1.92 (48,8)	8.5 (216)	4.7 (119)	30.6 (13,9)
	PN 100	9.6 (244)	–	1.92 (48,8)	8.5 (216)	4.7 (119)	36.4 (16,5)
	PN 160	10.2 (259)	–	1.92 (48,8)	8.5 (216)	–	38.7 (17,6)
	JIS 10K	7.7 (195)	–	1.92 (48,8)	8.5 (216)	4.7 (119)	19.5 (8,8)
JIS 20K JIS 40K	8.3 (210) 9.8 (249)	– –	1.92 (48,8) 1.92 (48,8)	8.5 (216) 8.5 (216)	4.7 (119) 4.7 (119)	20.1 (9,1) 28.3 (12,8)	

(1)  $\pm 0.14$  in. (3.6 mm)

(2)  $\pm 0.03$  in. (0.8 mm)

(3)  $\pm 0.20$  in. (5.1 mm)

(4) Add 0.2 lb (0,1 kg) for display option

# Product Data Sheet

00813-0100-4004, Rev FA  
Catalog 2008 - 2009

# Rosemount 8800D

TABLE 20. Flanged-Style Flowmeter (3-through 6 in./80 through 150mm Line Sizes) (Refer to previous drawing)

Nominal Size in. (mm)	Flange Rating	Face-to-face A in. (mm) <sup>(1)</sup>	A ANSI RTJ in. (mm)	Diameter B in. (mm) <sup>(2)</sup>	C in. (mm) <sup>(3)</sup>	D in. (mm)	Weight <sup>(4)</sup> lb (kg)
3 (80)	Class 150	9.9 (251)	10.4 (264)	2.87 (72,9)	9.1 (231)	5.3 (134)	36.9 (16,7)
	Class 300	10.6 (269)	11.2 (284)	2.87 (72,9)	9.1 (231)	5.3 (134)	46.1 (20,9)
	Class 600	11.4 (290)	11.5 (292)	2.87 (72,9)	9.1 (231)	5.3 (134)	52.1 (26,6)
	Class 900	12.9 (328)	13.0 (330)	2.87 (72,9)	9.1 (231)	5.3 (134)	75.5 (34,2)
	Class 1500	14.1 (358)	14.2 (361)	2.66 (67,6)	9.1 (231)	–	105.8 (48,0)
	PN 16/40	8.9 (226)	–	2.87 (72,9)	9.1 (231)	5.3 (134)	36.3 (16,5)
	PN 64	10.0 (254)	–	2.87 (72,9)	9.1 (231)	5.3 (134)	45.1 (20,5)
	PN 100	10.5 (267)	–	2.87 (72,9)	9.1 (231)	5.3 (134)	54.4 (24,7)
	PN 160	11.2 (284)	–	2.87 (72,9)	9.1 (231)	–	59.6 (27,0)
	JIS 10K	7.9 (200)	–	2.87 (72,9)	9.1 (231)	5.3 (134)	27.6 (12,5)
	JIS 20K	9.3 (235)	–	2.87 (72,9)	9.1 (231)	5.3 (134)	35.0 (15,9)
	JIS 40K	11.0 (280)	–	2.87 (72,9)	9.1 (231)	5.3 (134)	50.0 (22,7)
	4 (100)	Class 150	10.3 (262)	10.8 (274)	3.79 (96,3)	9.6 (244)	5.9 (149)
Class 300		11.0 (279)	11.6 (295)	3.79 (96,3)	9.6 (244)	5.9 (149)	70.8 (32,1)
Class 600		12.8 (325)	12.9 (328)	3.79 (96,3)	9.6 (244)	5.9 (149)	96.5 (43,8)
Class 900		13.8 (351)	13.9 (353)	3.79 (96,3)	9.6 (244)	5.9 (149)	119.7 (54,3)
Class 1500		14.5 (368)	14.6 (371)	3.43 (87,1)	9.6 (244)	–	157.9 (71,6)
PN 16		8.4 (213)	–	3.79 (96,3)	9.6 (244)	5.9 (149)	40.1 (18,2)
PN 40		9.4 (239)	–	3.79 (96,3)	9.6 (244)	5.9 (149)	49.2 (22,3)
PN 64		10.4 (264)	–	3.79 (96,3)	9.6 (244)	5.9 (149)	62.1 (28,2)
PN 100		11.3 (287)	–	3.79 (96,3)	9.6 (244)	5.9 (149)	78.5 (35,6)
PN 160		12.1 (307)	–	3.79 (96,3)	9.6 (244)	–	85.8 (38,9)
JIS 10K		8.7 (220)	–	3.79 (96,3)	9.6 (244)	5.9 (149)	37.0 (16,8)
JIS 20K		8.7 (220)	–	3.79 (96,3)	9.6 (244)	5.9 (149)	44.9 (20,4)
JIS 40K		11.8 (300)	–	3.79 (96,3)	9.6 (244)	5.9 (149)	75.3 (34,2)
6 (150)	Class 150	11.6 (295)	12.1 (307)	5.7 (144,8)	10.8 (274)	7.4 (187)	90.0 (40,8)
	Class 300	12.4 (315)	13.0 (330)	5.7 (144,8)	10.8 (274)	7.4 (187)	129.5 (58,7)
	Class 600	14.3 (363)	14.5 (368)	5.7 (144,8)	10.8 (274)	7.4 (187)	195.5 (88,7)
	Class 900	16.1 (409)	16.2 (411)	5.14 (130,6)	10.8 (274)	–	253.7 (115,1)
	Class 1500	18.6 (472)	18.8 (478)	5.14 (130,6)	10.8 (274)	–	376.0 (170,6)
	PN 16	8.9 (226)	–	5.7 (144,8)	10.8 (274)	7.4 (187)	75.6 (34,3)
	PN 40	10.5 (267)	–	5.7 (144,8)	10.8 (274)	7.4 (187)	95.3 (43,2)
	PN 64	12.1 (307)	–	5.7 (144,8)	10.8 (274)	7.4 (187)	138.8 (63,0)
	PN 100	13.7 (348)	–	5.7 (144,8)	10.8 (274)	7.4 (187)	168.5 (76,4)
	JIS 10K	10.6 (270)	–	5.7 (144,8)	10.8 (274)	7.4 (187)	79.8 (36,2)
	JIS 20K	10.6 (270)	–	5.7 (144,8)	10.8 (274)	7.4 (187)	97.7 (44,3)
	JIS 40K	14.2 (360)	–	5.7 (144,8)	10.8 (274)	7.4 (187)	175.9 (79,8)

(1) ±0.14 in. (3.6 mm)

(2) ±0.03 in. (0.8 mm)

(3) ±0.20 in. (5.1 mm)

(4) Add 0.2 lb (0,1 kg) for display option.

TABLE 21. Flanged-Style Flowmeter (8-through 12 in./200 through 300mm Line Sizes) (Refer to previous drawing)

Nominal Size in. (mm)	Flange Rating	Face-to-face A in. (mm) <sup>(1)</sup>	A ANSI RTJ in. (mm)	Diameter B in. (mm) <sup>(2)</sup>	C in. (mm) <sup>(3)</sup>	D in. (mm)	Weight <sup>(4)</sup> lb (kg)
8 (200)	Class 150	13.6 (345)	14.1 (358)	7.55 (191,8)	11.7 (297)	8.3 (210)	139.6 (63,3)
	Class 300	14.3 (363)	15.0 (381)	7.55 (191,8)	11.7 (297)	8.3 (210)	196.2 (89,0)
	Class 600	16.6 (422)	16.7 (424)	7.55 (191,8)	11.7 (297)	8.3 (210)	295.0 (133,8)
	Class 900	18.8 (478)	19.0 (483)	6.62 (168,1)	11.7 (297)	–	420.4 (190,7)
	Class 1500	22.8 (579)	23.2 (589)	6.62 (168,1)	11.7 (297)	–	646.0 (293,0)
	PN 10	10.5 (266)	–	7.55 (191,8)	11.7 (297)	8.3 (210)	109.6 (49,7)
	PN 16	10.5 (266)	–	7.55 (191,8)	11.7 (297)	8.3 (210)	108.5 (49,2)
	PN 25	11.9 (302)	–	7.55 (191,8)	11.7 (297)	8.3 (210)	136.3 (61,8)
	PN 40	12.5 (318)	–	7.55 (191,8)	11.7 (297)	8.3 (210)	154.8 (70,2)
	PN 64	14.2 (361)	–	7.55 (191,8)	11.7 (297)	8.3 (210)	214.6 (97,3)
	PN 100	15.8 (401)	–	7.55 (191,8)	11.7 (297)	8.3 (210)	279.9 (127)
	JIS 10K	12.2 (310)	–	7.55 (191,8)	11.7 (297)	8.3 (210)	109.9 (49,9)
	JIS 20K	12.2 (310)	–	7.55 (191,8)	11.7 (297)	8.3 (210)	134.3 (60,9)
	JIS 40K	16.5 (420)	–	7.55 (191,8)	11.7 (297)	8.3 (210)	255.7 (116)
	10 (250)	Class 150	14.6 (371)	15.1 (384)	9.56 (243)	12.8 (325)	9.3 (236)
Class 300		15.8 (401)	16.4 (417)	9.56 (243)	12.8 (325)	9.3 (236)	285.2 (129)
Class 600		19.1 (485)	19.2 (488)	9.56 (243)	12.8 (325)	9.3 (236)	475.3 (216)
PN 10		11.9 (302)	–	9.56 (243)	12.8 (325)	9.3 (236)	156.3 (71)
PN 16		12.1 (307)	–	9.56 (243)	12.8 (325)	9.3 (236)	161.1 (73)
PN 25		13.5 (343)	–	9.56 (243)	12.8 (325)	9.3 (236)	197.4 (90)
PN 40		14.8 (376)	–	9.56 (243)	12.8 (325)	9.3 (236)	245.3 (111)
PN 64		16.4 (417)	–	9.56 (243)	12.8 (325)	9.3 (236)	306.3 (139)
PN 100		18.9 (480)	–	9.56 (243)	12.8 (325)	9.3 (236)	443.0 (201)
JIS 10K		14.6 (371)	–	9.56 (243)	12.8 (325)	9.3 (236)	173.3 (79)
JIS 20K		14.6 (371)	–	9.56 (243)	12.8 (325)	9.3 (236)	220.5 (100)
JIS 40K		18.1 (460)	–	9.56 (243)	12.8 (325)	9.3 (236)	377.3 (171)
12 (300)	Class 150	16.8 (427)	17.3 (439)	11.38 (289)	13.7 (348)	10.1 (256)	296.0 (134)
	Class 300	18.0 (457)	18.7 (475)	11.38 (289)	13.7 (348)	10.1 (256)	413.2 (187)
	Class 600	20.5 (521)	20.7 (526)	11.38 (289)	13.7 (348)	10.1 (256)	592.2 (269)
	PN 10	13.2 (335)	–	11.38 (289)	13.7 (348)	10.1 (256)	203.1 (92)
	PN 16	13.9 (353)	–	11.38 (289)	13.7 (348)	10.1 (256)	223.4 (101)
	PN 25	15.0 (381)	–	11.38 (289)	13.7 (348)	10.1 (256)	267.8 (121)
	PN 40	16.9 (429)	–	11.38 (289)	13.7 (348)	10.1 (256)	345.7 (157)
	PN 64	18.8 (478)	–	11.38 (289)	13.7 (348)	10.1 (256)	428.5 (194)
	PN 100	21.2 (538)	–	11.38 (289)	13.7 (348)	10.1 (256)	640.8 (291)
	JIS 10K	15.7 (399)	–	11.38 (289)	13.7 (348)	10.1 (256)	224.5 (102)
	JIS 20K	15.7 (399)	–	11.38 (289)	13.7 (348)	10.1 (256)	287.1 (130)
	JIS 40K	19.7 (500)	–	11.38 (289)	13.7 (348)	10.1 (256)	504.7 (229)

(1) ±0.14 in. (3.6 mm)

(2) ±0.03 in. (0.8 mm)

(3) ±0.20 in. (5.1 mm)

(4) Add 0.2 lb (0,1 kg) for display option.



# Product Data Sheet

00813-0100-4004, Rev FA  
Catalog 2008 - 2009

# Rosemount 8800D

FIGURE 3. Rosemount 8800DR Reducer™ Flowmeter Dimensional Drawings (1-through 12 in./25 through 300 mm Line Sizes)

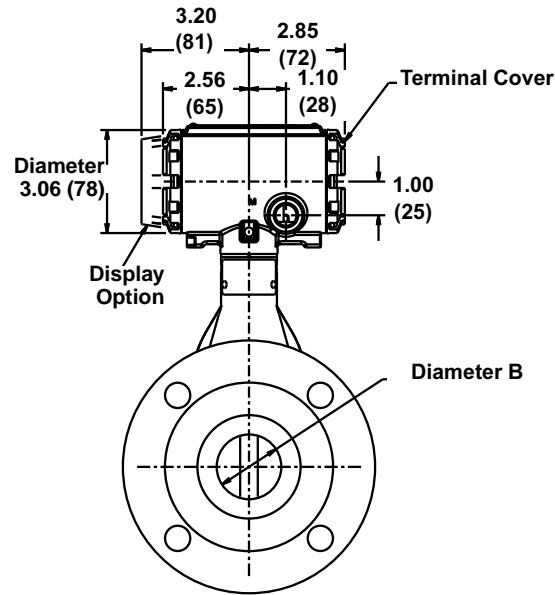
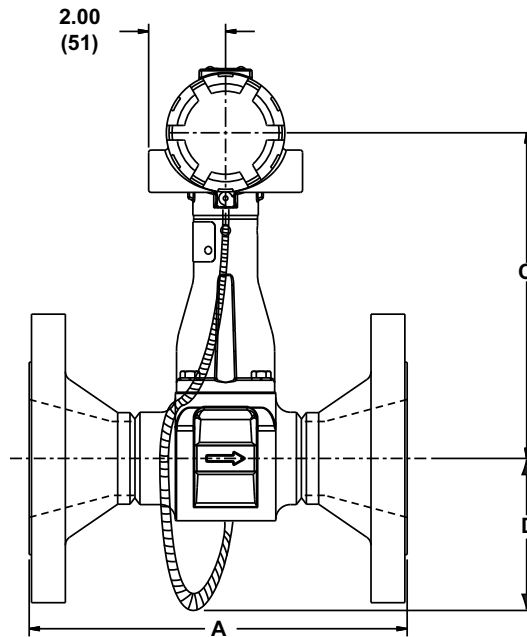
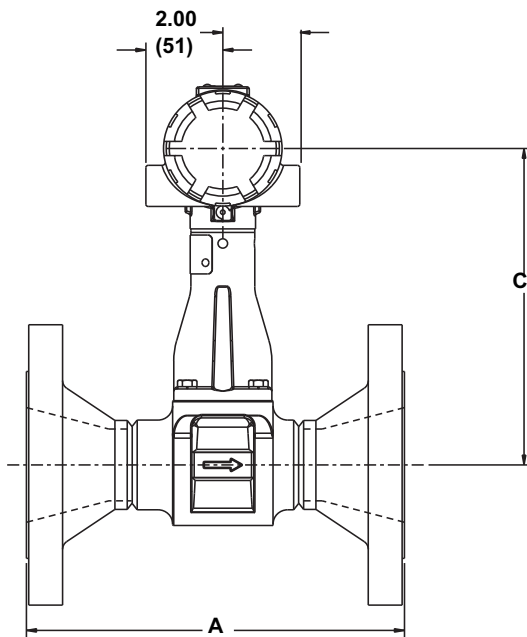

Diagram illustrated without MTA Option

Diagram illustrated with MTA Option



**NOTE**  
Dimensions are in inches (millimeters)

# Rosemount 8800D

## Product Data Sheet

00813-0100-4004, Rev FA

Catalog 2008 - 2009

TABLE 22. Reducer Flowmeter (1-through 3in./25 through 80 mm Line Sizes)

Nominal Size in. (mm)	Flange Rating	Face-to-face A in. (mm) <sup>(1)</sup>	A-ANSI RTJ in. (mm)	Diameter B in. (mm) <sup>(2)</sup>	C in. (mm) <sup>(3)</sup>	D in. (mm)	Weight <sup>(4)</sup> lb (kg)
1 (25)	Class 150	7.5 (191)	8.0 (203)	0.54 (13,7)	7.6 (193)	–	11.56 (5,24)
	Class 300	8.0 (203)	8.5 (216)	0.54 (13,7)	7.6 (193)	–	14.22 (6,45)
	Class 600	8.5 (216)	8.5 (216)	0.54 (13,7)	7.6 (193)	–	15.11 (6,85)
	Class 900	9.4 (239)	9.4 (239)	0.54 (13,7)	7.6 (193)	–	20.70 (9,40)
	PN 16/40	6.3 (160)	–	0.54 (13,7)	7.6 (193)	–	12.64 (5,73)
	PN 100	7.7 (195)	–	0.54 (13,7)	7.6 (193)	–	18.44 (8,36)
PN 160	7.7 (195)	–	0.54 (13,7)	7.6 (193)	–	18.44 (8,36)	
1 ½ (40)	Class 150	8.2 (208)	8.7 (221)	0.95 (24,1)	7.7 (196)	–	15.81 (7,17)
	Class 300	8.7 (221)	9.2 (234)	0.95 (24,1)	7.7 (196)	–	21.20 (9,62)
	Class 600	9.4 (239)	9.4 (239)	0.95 (24,1)	7.7 (196)	–	23.77 (10,78)
	Class 900	10.4 (264)	10.4 (264)	0.95 (24,1)	7.7 (196)	–	34.98 (15,87)
	PN 16/40	6.9 (175)	–	0.95 (24,1)	7.7 (196)	–	17.50 (7,94)
	PN 100	8.2 (208)	–	0.95 (24,1)	7.7 (196)	–	26.20 (11,88)
PN 160	8.4 (213)	–	0.95 (24,1)	7.7 (196)	–	27.67 (12,55)	
2 (50)	Class 150	9.3 (236)	9.8 (249)	1.49 (37,8)	8.1 (206)	–	22.61 (10,26)
	Class 300	9.8 (249)	10.4 (264)	1.49 (37,8)	8.1 (206)	–	26.76 (12,14)
	Class 600	10.5 (267)	10.7 (271)	1.49 (37,8)	8.1 (206)	–	30.59 (13,88)
	Class 900	12.8 (325)	12.9 (328)	1.49 (37,8)	8.1 (206)	–	60.76 (27,56)
	PN 16/40	8.0 (203)	–	1.49 (37,8)	8.1 (206)	–	23.52 (10,67)
	PN 64	9.2 (234)	–	1.49 (37,8)	8.1 (206)	–	31.28 (14,19)
	PN 100	9.6 (244)	–	1.49 (37,8)	8.1 (206)	–	37.25 (16,90)
PN 160	10.2 (259)	–	1.49 (37,8)	8.1 (206)	–	39.64 (17,98)	
3 (80)	Class 150	9.9 (251)	10.4 (264)	1.92 (48,8)	8.5 (216)	4.7 (119)	33.15 (15,04)
	Class 300	10.6 (269)	11.2 (284)	1.92 (48,8)	8.5 (216)	4.7 (119)	42.66 (19,35)
	Class 600	11.4 (290)	11.5 (292)	1.92 (48,8)	8.5 (216)	4.7 (119)	49.46 (22,43)
	Class 900	12.9 (328)	13.0 (330)	1.92 (48,8)	8.5 (216)	4.7 (119)	73.28 (33,24)
	PN 16/40	8.9 (226)	–	1.92 (48,8)	8.5 (216)	4.7 (119)	33.30 (15,10)
	PN 64	10.0 (254)	–	1.92 (48,8)	8.5 (216)	4.7 (119)	42.45 (19,25)
	PN 100	10.5 (267)	–	1.92 (48,8)	8.5 (216)	4.7 (119)	52.21 (23,68)
PN 160	11.2 (284)	–	1.92 (48,8)	8.5 (216)	4.7 (119)	57.94 (26,28)	

(1) ±0.14 in. (3.6 mm)

(2) ±0.03 in. (0.8 mm)

(3) ±0.20 in. (5.1 mm)

(4) Add 0.2 lb (0,1 kg) for display option.

# Product Data Sheet

00813-0100-4004, Rev FA  
Catalog 2008 - 2009

# Rosemount 8800D

TABLE 23. Reducer Flowmeter (4-through 12 in./100 through 300mm Line Sizes) (Refer to previous drawing)

Nominal Size in. (mm)	Flange Rating	Face-to-face A in. (mm) <sup>(1)</sup>	A ANSI RTJ in. (mm)	Diameter B in. (mm) <sup>(2)</sup>	C in. (mm) <sup>(3)</sup>	D in. (mm)	Weight <sup>(4)</sup> lb (kg)
4 (100)	Class 150	10.3 (262)	10.8 (274)	2.87 (72,9)	9.1 (231)	5.3 (134)	46.33 (21,01)
	Class 300	11.0 (279)	11.6 (295)	2.87 (72,9)	9.1 (231)	5.3 (134)	67.04 (30,41)
	Class 600	12.8 (325)	12.9 (328)	2.87 (72,9)	9.1 (231)	5.3 (134)	94.26 (42,76)
	Class 900	13.8 (351)	13.9 (353)	2.87 (72,9)	9.1 (231)	5.3 (134)	118.04 (53,54)
	PN 16	8.4 (213)	–	2.87 (72,9)	9.1 (231)	5.3 (134)	36.36 (16,49)
	PN 40	9.4 (239)	–	2.87 (72,9)	9.1 (231)	5.3 (134)	45.89 (20,81)
	PN 64	10.4 (264)	–	2.87 (72,9)	9.1 (231)	5.3 (134)	59.72 (27,09)
	PN 100	11.3 (287)	–	2.87 (72,9)	9.1 (231)	5.3 (134)	76.73 (34,80)
6 (150)	Class 150	11.6 (295)	12.1 (307)	3.79 (96,3)	9.6 (244)	5.9 (149)	70.27 (31,87)
	Class 300	12.4 (315)	13.0 (330)	3.79 (96,3)	9.6 (244)	5.9 (149)	113.09 (51,30)
	Class 600	14.3 (363)	14.5 (368)	3.79 (96,3)	9.6 (244)	5.9 (149)	185.13 (83,97)
	Class 900	16.1 (409)	16.2 (411)	3.79 (96,3)	9.6 (244)	5.9 (149)	246.33 (111,73)
	PN 16	8.9 (226)	–	3.79 (96,3)	9.6 (244)	5.9 (149)	59.20 (26,85)
	PN 40	10.5 (267)	–	3.79 (96,3)	9.6 (244)	5.9 (149)	81.94 (37,17)
	PN 64	12.1 (307)	–	3.79 (96,3)	9.6 (244)	5.9 (149)	125.36 (56,86)
	PN 100	13.7 (348)	–	3.79 (96,3)	9.6 (244)	5.9 (149)	162.29 (73,61)
8 (200)	Class 150	13.6 (345)	14.1 (358)	5.70 (144,8)	10.8 (274)	7.4 (187)	133.14 (60,39)
	Class 300	14.3 (363)	15.0 (381)	5.70 (144,8)	10.8 (274)	7.4 (187)	195.54 (88,69)
	Class 600	16.6 (422)	16.7 (424)	5.70 (144,8)	10.8 (274)	7.4 (187)	305.18 (138,43)
	PN 10	10.5 (266)	–	5.70 (144,8)	10.8 (274)	7.4 (187)	100.92 (45,78)
	PN 16	10.5 (266)	–	5.70 (144,8)	10.8 (274)	7.4 (187)	100.92 (45,78)
	PN 25	11.9 (302)	–	5.70 (144,8)	10.8 (274)	7.4 (187)	134.05 (60,80)
	PN 40	12.5 (318)	–	5.70 (144,8)	10.8 (274)	7.4 (187)	155.00 (70,31)
	PN 64	14.2 (361)	–	5.70 (144,8)	10.8 (274)	7.4 (187)	220.68 (100,10)
10 (250)	Class 150	14.6 (371)	15.1 (384)	7.55 (191,8)	11.7 (297)	8.3 (210)	182.45 (82,76)
	Class 300	15.8 (401)	16.4 (417)	7.55 (191,8)	11.7 (297)	8.3 (210)	281.66 (127,76)
	Class 600	19.1 (485)	19.2 (488)	7.55 (191,8)	11.7 (297)	8.3 (210)	489.89 (222,21)
	PN 10	11.9 (302)	–	7.55 (191,8)	11.7 (297)	8.3 (210)	138.63 (62,88)
	PN 16	12.1 (307)	–	7.55 (191,8)	11.7 (297)	8.3 (210)	148.58 (67,39)
	PN 25	13.5 (343)	–	7.55 (191,8)	11.7 (297)	8.3 (210)	191.00 (86,64)
	PN 40	14.8 (376)	–	7.55 (191,8)	11.7 (297)	8.3 (210)	245.85 (111,52)
	PN 64	16.4 (417)	–	7.55 (191,8)	11.7 (297)	8.3 (210)	314.13 (142,49)
12 (300)	Class 150	16.8 (427)	17.3 (439)	9.56 (242,8)	12.8 (325)	9.3 (236)	281.98 (127,90)
	Class 300	18.0 (457)	18.7 (475)	9.56 (242,8)	12.8 (325)	9.3 (236)	412.18 (186,96)
	Class 600	20.5 (521)	20.7 (526)	9.56 (242,8)	12.8 (325)	9.3 (236)	609.89 (296,64)
	PN 10	13.2 (335)	–	9.56 (242,8)	12.8 (325)	9.3 (236)	188.28 (85,40)
	PN 16	13.9 (353)	–	9.56 (242,8)	12.8 (325)	9.3 (236)	211.79 (96,07)
	PN 25	15.0 (381)	–	9.56 (242,8)	12.8 (325)	9.3 (236)	262.45 (119,05)
	PN 40	16.9 (429)	–	9.56 (242,8)	12.8 (325)	9.3 (236)	349.92 (158,72)
	PN 64	18.8 (478)	–	9.56 (242,8)	12.8 (325)	9.3 (236)	444.21 (201,49)
PN 100	21.2 (538)	–	9.56 (242,8)	12.8 (325)	9.3 (236)	672.07 (304,85)	

(1) ±0.14 in. (3.6 mm)

(2) ±0.03 in. (0.8 mm)

(3) ±0.20 in. (5.1 mm)

(4) Add 0.2 lb (0,1 kg) for display option.

# Rosemount 8800D

FIGURE 4. Wafer-Style Dimensional Drawings ( $1/2$ -through 8 in./15 through 200 mm Line Sizes)

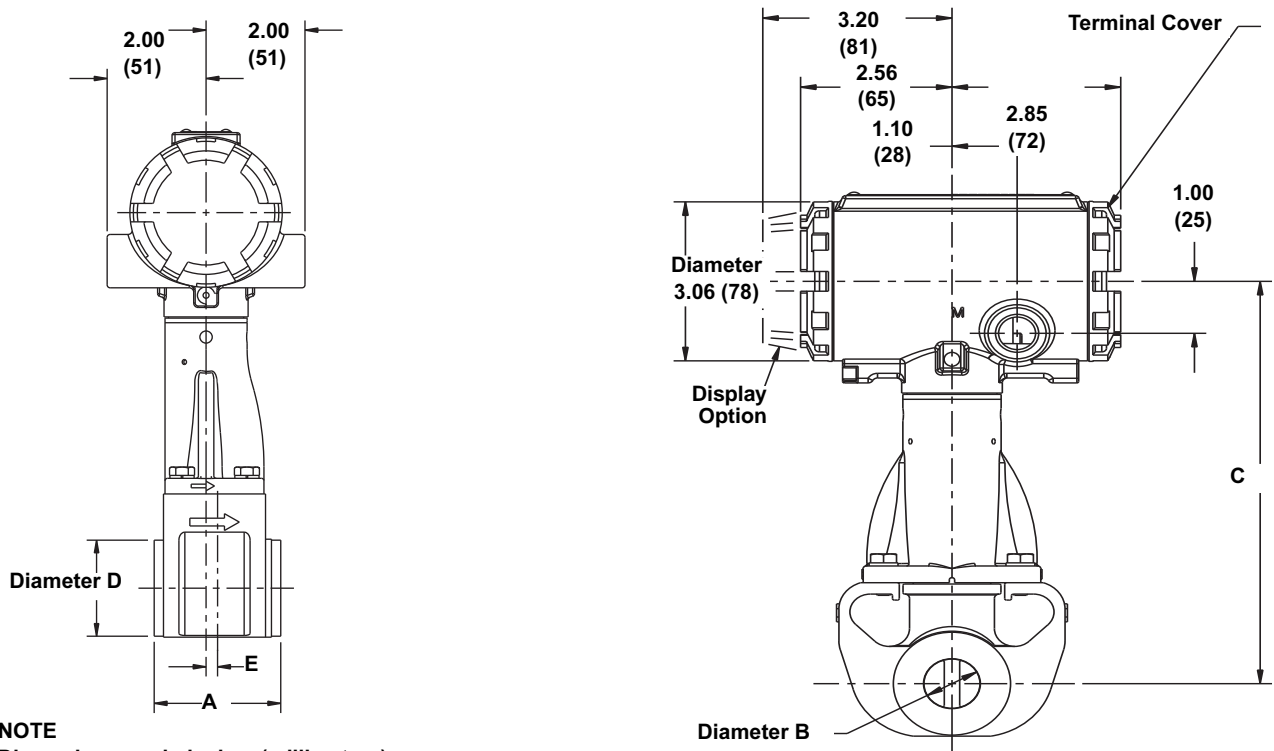

**NOTE**  
Dimensions are in inches (millimeters)  
Electronics housing may be rotated in 90 degree increments

TABLE 24. Rosemount 8800D Wafer-Style Meter

Nominal Size in. (mm)	Face-to-face A in. (mm) <sup>(1)</sup>	Diameter B in. (mm) <sup>(2)</sup>	C in. (mm) <sup>(3)</sup>	Diameter D in. (mm)	E in. (mm)	Weight lb (kg) <sup>(4)</sup>
1/2 (15)	2.56 (65)	0.54 (13,7)	7.63 (194)	1.38 (35,1)	0.23 (5,9)	7.3 (3,3)
1 (25)	2.56 (65)	0.95 (24,1)	7.74 (197)	1.98 (50,3)	0.23 (5,9)	7.4 (3,4)
1 1/2 (40)	2.56 (65)	1.49 (37,8)	8.14 (207)	2.87 (72,9)	0.18 (4,6)	10.0 (4,5)
2 (50)	2.56 (65)	1.92 (49)	8.85 (225)	3.86 (98)	0.12 (3)	10.6 (4,8)
3 (80)	2.56 (65)	2.87 (73)	9.62 (244)	5.00 (127)	0.25 (6)	13.6 (6,2)
4 (100)	3.42 (87)	3.79 (96)	10.48 (266)	6.20 (158)	0.44 (11)	21.4 (9,7)
6 (150)	4.99 (127)	5.70 (145)	10.75 (273)	8.50 (216)	1.11 (28)	49.1 (22,3)
8 (200)	6.60 (168)	7.55 (192)	11.67 (296)	10.62 (270)	0.89 (23)	85 (38,6)

(1)  $\pm 0.04$  in. (1.0 mm)

(2)  $\pm 0.03$  in. (0.8 mm)

(3)  $\pm 0.20$  in. (5.1 mm)

(4) Add 0.2 lb (0,1 kg) for display option.

**Product Data Sheet**

00813-0100-4004, Rev FA  
 Catalog 2008 - 2009

**Rosemount 8800D**

FIGURE 5. Vortex Dual-Sensor Style Flowmeter Dimensional Drawings  
 (6 - 8 in (150 - 200mm) with 900# or 1500# flanges. See Figure 6.)

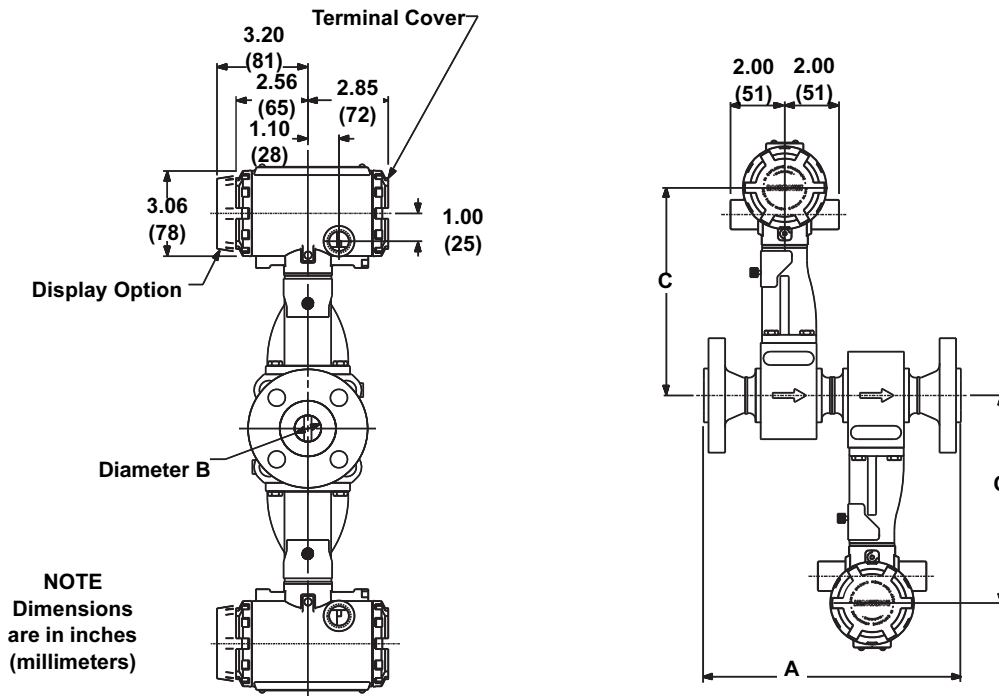
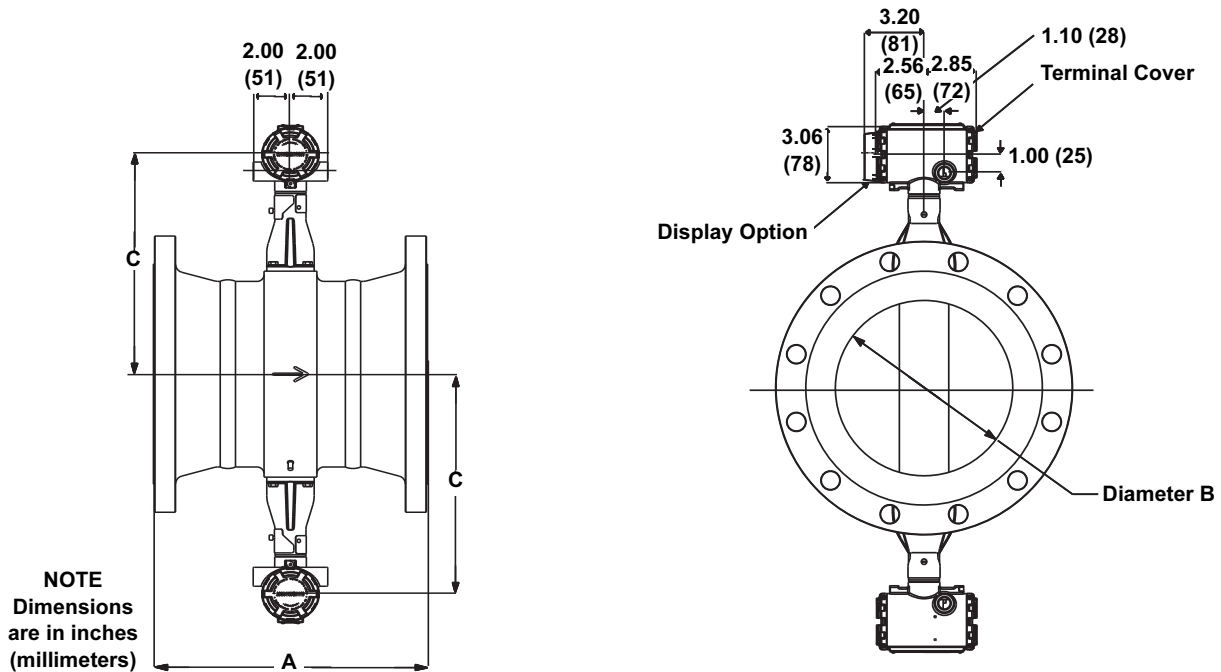

FIGURE 6. Vortex Dual-Sensor Style Flowmeter Dimensional Drawings  
 (6 - 8 in (150 - 200mm) with 900# or 1500# flanges and all 10 - 12 in. (250-300mm) line sizes)



# Rosemount 8800D

## Product Data Sheet

00813-0100-4004, Rev FA

Catalog 2008 - 2009

TABLE 25. Vortex Dual-Sensor Style Flowmeter (1/2-through 3 in./15 through 80 mm Line Sizes)

Nominal Size in. (mm)	Flange Rating	Face-to-face A in. (mm) <sup>(1)</sup>	A ANSI RTJ in. (mm)	Diameter B in. (mm) <sup>(2)</sup>	C in. (mm) <sup>(3)</sup>	Weight lb (kg) <sup>(4)</sup>	
1/2 (15)	Class 150	12.0 (305)	–	0.54 (13,7)	7.6 (193)	16.2 (7,4)	
	Class 300	12.3 (312)	12.8 (325)	0.54 (13,7)	7.6 (193)	17.4 (7,9)	
	Class 600	12.8 (325)	12.8 (325)	0.54 (13,7)	7.6 (193)	17.9 (8,1)	
	Class 900	13.5 (343)	13.5 (343)	0.54 (13,7)	7.6 (193)	22.4 (10,2)	
	PN 16/40	11.2 (284)	–	0.54 (13,7)	7.6 (193)	17.2 (7,8)	
	PN 100	11.8 (300)	–	0.54 (13,7)	7.6 (193)	19.2 (8,7)	
	JIS 10K/20K	11.4 (290)	–	0.54 (13,7)	7.6 (193)	17.1 (7,8)	
	JIS 40K	12.4 (315)	–	0.54 (13,7)	7.6 (193)	20.6 (9,3)	
1 (25)	Class 150	15.1 (384)	15.6 (396)	0.95 (24,1)	7.7 (196)	19.8 (9,0)	
	Class 300	15.6 (396)	16.1 (409)	0.95 (24,1)	7.7 (196)	22.5 (10,2)	
	Class 600	16.1 (409)	16.1 (409)	0.95 (24,1)	7.7 (196)	23.3 (10,6)	
	Class 900	17.0 (432)	17.0 (432)	0.95 (24,1)	7.7 (196)	31.8 (14,4)	
	Class 1500	17.0 (432)	17.0 (432)	0.95 (24,1)	7.7 (196)	31.8 (14,4)	
	PN 16/40	13.9 (353)	–	0.95 (24,1)	7.7 (196)	21.0 (9,5)	
	PN 100	15.3 (389)	–	0.95 (24,1)	7.7 (196)	27.0 (12,3)	
	PN 160	15.3 (389)	–	0.95 (24,1)	7.7 (196)	27.0 (12,3)	
	JIS 10K/20K	14.1 (358)	–	0.95 (24,1)	7.7 (196)	22.1 (10,0)	
	JIS 40K	15.5 (394)	–	0.95 (24,1)	7.7 (196)	25.8 (11,7)	
1 1/2 (40)	Class 150	11.3 (287)	11.8 (300)	1.49 (37,8)	8.1 (206)	27.0 (12,3)	
	Class 300	11.8 (300)	12.3 (312)	1.49 (37,8)	8.1 (206)	32.4 (14,7)	
	Class 600	12.5 (318)	12.5 (318)	1.49 (37,8)	8.1 (206)	34.8 (15,8)	
	Class 900	13.5 (343)	13.5 (343)	1.49 (37,8)	8.1 (206)	45.7 (20,7)	
	Class 1500	13.5 (343)	13.5 (343)	1.49 (37,8)	8.1 (206)	45.7 (20,7)	
	PN 16/40	10.0 (254)	–	1.49 (37,8)	8.1 (206)	28.7 (13,0)	
	PN 100	11.3 (287)	–	1.49 (37,8)	8.1 (206)	37.4 (17,0)	
	PN 160	11.5 (292)	–	1.49 (37,8)	8.1 (206)	38.8 (17,6)	
	JIS 10K/20K	10.4 (264)	–	1.49 (37,8)	8.1 (206)	27.9 (12,6)	
	JIS 40K	11.5 (292)	–	1.49 (37,8)	8.1 (206)	34.9 (15,8)	
2 (50)	Class 150	13.0 (330)	13.6 (345)	1.92 (48,8)	8.5 (216)	31.9 (14,5)	
	Class 300	13.6 (345)	14.1 (358)	1.92 (48,8)	8.5 (216)	35.9 (16,3)	
	Class 600	14.3 (363)	14.3 (363)	1.92 (48,8)	8.5 (216)	39.5 (17,9)	
	Class 900	16.6 (422)	16.7 (424)	1.92 (48,8)	8.5 (216)	69.2 (31,4)	
	Class 1500	15.6 (396)	15.7 (399)	1.67 (42,4)	8.5 (216)	72.0 (32,6)	
	PN 16/40	11.8 (300)	–	1.92 (48,8)	8.5 (216)	32.9 (14,9)	
	PN 64	12.9 (328)	–	1.92 (48,8)	8.5 (216)	40.5 (18,4)	
	PN 100	13.4 (340)	–	1.92 (48,8)	8.5 (216)	46.2 (21,0)	
	PN 160	14.0 (356)	–	1.92 (48,8)	8.5 (216)	48.5 (22,0)	
	JIS 10K	11.5 (292)	–	1.92 (48,8)	8.5 (216)	29.1 (13,2)	
	JIS 20K	12.1 (307)	–	1.92 (48,8)	8.5 (216)	29.7 (13,5)	
	JIS 40K	13.6 (345)	–	1.92 (48,8)	8.5 (216)	37.9 (17,2)	
	3 (80)	Class 150	14.3 (363)	14.8 (376)	2.87 (72,9)	9.1 (231)	50.3 (22,8)
		Class 300	15.0 (381)	15.7 (399)	2.87 (72,9)	9.1 (231)	59.5 (27,0)
Class 600		15.8 (401)	15.8 (401)	2.87 (72,9)	9.1 (231)	65.5 (29,7)	
Class 900		17.3 (439)	17.4 (442)	2.87 (72,9)	9.1 (231)	88.9 (40,3)	
Class 1500		18.5 (470)	18.6 (472)	2.60 (66,0)	9.1 (232)	123.0 (55,8)	
PN 16/40		13.4 (340)	–	2.87 (72,9)	9.1 (231)	49.7 (22,5)	
PN 64		14.5 (367)	–	2.87 (72,9)	9.1 (231)	58.5 (26,5)	
PN 100		14.9 (378)	–	2.87 (72,9)	9.1 (231)	67.8 (30,8)	
PN 160		15.6 (396)	–	2.87 (72,9)	9.1 (231)	73.0 (33,1)	
JIS 10K		12.3 (312)	–	2.87 (72,9)	9.1 (231)	41.0 (18,6)	
JIS 20K		13.7 (348)	–	2.87 (72,9)	9.1 (231)	48.4 (22,0)	
JIS 40K		15.5 (394)	–	2.87 (72,9)	9.1 (231)	63.4 (28,8)	

(1) ±0.14 in. (3.6 mm)

(2) ±0.03 in. (0.8 mm)

(3) ±0.20 in. (5.1 mm)

(4) Add 0.4 lb (0,2 kg) for display option.

# Product Data Sheet

00813-0100-4004, Rev FA  
Catalog 2008 - 2009

# Rosemount 8800D

TABLE 26. Vortex Dual-Sensor Style Flowmeter (4- through 12 in./100 through 300 mm Line Sizes)

Nominal Size in. (mm)	Flange Rating	Face-to-face A in. (mm) <sup>(1)</sup>	A ANSI RTJ in. (mm)	Diameter B in. (mm) <sup>(2)</sup>	C in. (mm) <sup>(3)</sup>	Weight lb (kg) <sup>(4)</sup>
4 (100)	Class 150	15.2 (386)	15.7 (399)	3.79 (96,3)	9.6 (244)	68.1 (30,9)
	Class 300	16.0 (406)	16.6 (422)	3.79 (96,3)	9.6 (244)	88.2 (40,0)
	Class 600	17.7 (450)	17.7 (450)	3.79 (96,3)	9.6 (244)	113.9 (51,7)
	Class 900	18.7 (475)	18.9 (480)	3.79 (96,3)	9.6 (244)	137.1 (62,2)
	Class 1500	20.0 (509)	20.2 (512)	3.40 (86,4)	9.6 (244)	182 (82,6)
	PN 16	13.3 (338)	–	3.79 (96,3)	9.6 (244)	57.6 (26,1)
	PN 40	14.4 (366)	–	3.79 (96,3)	9.6 (244)	66.6 (30,2)
	PN 64	15.4 (391)	–	3.79 (96,3)	9.6 (244)	79.6 (36,1)
	PN 100	16.3 (414)	–	3.79 (96,3)	9.6 (244)	95.9 (43,5)
	PN 160	17.1 (434)	–	3.79 (96,3)	9.6 (244)	103.2 (46,8)
	JIS 10K	13.6 (345)	–	3.79 (96,3)	9.6 (244)	55.4 (25,1)
	JIS 20K	13.6 (345)	–	3.79 (96,3)	9.6 (244)	63.2 (28,7)
JIS 40K	16.8 (427)	–	3.79 (96,3)	9.6 (244)	93.7 (42,5)	
6 (150)	Class 150	19.4 (493)	19.9 (505)	5.7 (144,8)	10.8 (274)	126.4 (57,3)
	Class 300	20.2 (513)	20.8 (528)	5.7 (144,8)	10.8 (274)	165.9 (75,3)
	Class 600	22.2 (564)	22.3 (566)	5.7 (144,8)	10.8 (274)	231.9 (105,2)
	Class 900	16.1 (409)	16.2 (411)	5.14 (130,6)	10.8 (274)	266 (120,6)
	Class 1500	18.6 (472)	18.8 (478)	5.14 (130,6)	10.8 (274)	378 (171,4)
	PN 16	16.8 (427)	–	5.7 (144,8)	10.8 (274)	112.0 (50,8)
	PN 40	18.3 (465)	–	5.7 (144,8)	10.8 (274)	131.7 (59,7)
	PN 64	19.9 (505)	–	5.7 (144,8)	10.8 (274)	175.2 (79,5)
	PN 100	21.5 (546)	–	5.7 (144,8)	10.8 (274)	204.8 (92,9)
	JIS 10K	18.5 (470)	–	5.7 (144,8)	10.8 (274)	124.0 (56,2)
	JIS 20K	18.5 (470)	–	5.7 (144,8)	10.8 (274)	141.9 (64,4)
	JIS 40K	22.0 (559)	–	5.7 (144,8)	10.8 (274)	220.1 (99,8)
8 (200)	Class 150	24.0 (610)	24.5 (622)	7.55 (191,8)	11.7 (297)	190.1 (86,2)
	Class 300	24.8 (630)	25.4 (645)	7.55 (191,8)	11.7 (297)	246.7 (111,9)
	Class 600	27.0 (686)	27.1 (688)	7.55 (191,8)	11.7 (297)	345.5 (156,7)
	Class 900	18.4 (467)	19.0 (483)	6.62 (168,1)	11.7 (297)	479 (217,3)
	Class 1500	22.8 (580)	23.2 (589)	6.62 (168,1)	11.7 (297)	637 (288,9)
	PN 10	20.9 (531)	–	7.55 (191,8)	11.7 (297)	160.2 (72,7)
	PN 16	20.9 (531)	–	7.55 (191,8)	11.7 (297)	159.0 (72,1)
	PN 25	22.3 (566)	–	7.55 (191,8)	11.7 (297)	186.9 (83,4)
	PN 40	22.9 (582)	–	7.55 (191,8)	11.7 (297)	205.4 (93,2)
	PN 64	24.7 (627)	–	7.55 (191,8)	11.7 (297)	265.1 (120,2)
	PN 100	26.3 (668)	–	7.55 (191,8)	11.7 (297)	330.4 (149,9)
	JIS 10K	22.6 (574)	–	7.55 (191,8)	11.7 (297)	178.2 (80,8)
JIS 20K	22.6 (574)	–	7.55 (191,8)	11.7 (297)	202.6 (91,9)	
JIS 40K	27.0 (686)	–	7.55 (191,8)	11.7 (297)	324.0 (147,0)	
10 (250)	Class 150	14.6 (371)	15.1 (384)	9.56 (243)	12.8 (325)	201.5 (91)
	Class 300	15.8 (401)	16.4 (417)	9.56 (243)	12.8 (325)	289.5 (131)
	Class 600	19.1 (485)	19.2 (488)	9.56 (243)	12.8 (325)	479.6 (218)
	PN 10	11.9 (302)	–	9.56 (243)	12.8 (325)	160.6 (73)
	PN 16	12.1 (307)	–	9.56 (243)	12.8 (325)	165.4 (75)
	PN 25	13.5 (343)	–	9.56 (243)	12.8 (325)	210.7 (96)
	PN 40	14.8 (376)	–	9.56 (243)	12.8 (325)	249.6 (113)
	PN 64	16.4 (417)	–	9.56 (243)	12.8 (325)	310.6 (141)
	PN 100	18.9 (480)	–	9.56 (243)	12.8 (325)	447.3 (203)
	JIS 10K	14.6 (371)	–	9.56 (243)	12.8 (325)	177.6 (81)
	JIS 20K	14.6 (371)	–	9.56 (243)	12.8 (325)	224.8 (102)
	JIS 40K	18.1 (460)	–	9.56 (243)	12.8 (325)	381.6 (173)
12 (300)	Class 150	16.8 (427)	17.3 (439)	11.38 (289)	13.7 (348)	300.3 (136)
	Class 300	18.0 (457)	18.7 (475)	11.38 (289)	13.7 (348)	417.5 (189)
	Class 600	20.5 (521)	20.7 (526)	11.38 (289)	13.7 (348)	596.5 (271)
	PN 10	13.2 (335)	–	11.38 (289)	13.7 (348)	207.4 (94)
	PN 16	13.9 (353)	–	11.38 (289)	13.7 (348)	227.7 (103)
	PN 25	15.0 (381)	–	11.38 (289)	13.7 (348)	272.1 (123)
	PN 40	16.9 (429)	–	11.38 (289)	13.7 (348)	350.0 (159)
	PN 64	18.8 (478)	–	11.38 (289)	13.7 (348)	432.8 (196)
	PN 100	21.2 (538)	–	11.38 (289)	13.7 (348)	645.1 (293)
	JIS 10K	15.7 (399)	–	11.38 (289)	13.7 (348)	228.8 (104)
	JIS 20K	15.7 (399)	–	11.38 (289)	13.7 (348)	291.4 (132)
	JIS 40K	19.7 (500)	–	11.38 (289)	13.7 (348)	508.9 (231)

(1) ±0.14 in. (3.6 mm)

(2) ±0.03 in. (0.8 mm)

(3) ±0.20 in. (5.1 mm)

(4) Add 0.4 Lb (0,2 kg) for display option.

FIGURE 7. Vortex weld-end style flowmeter dimensional drawings  
 (1/2 - 4 in. (15 - 100 mm) line sizes)

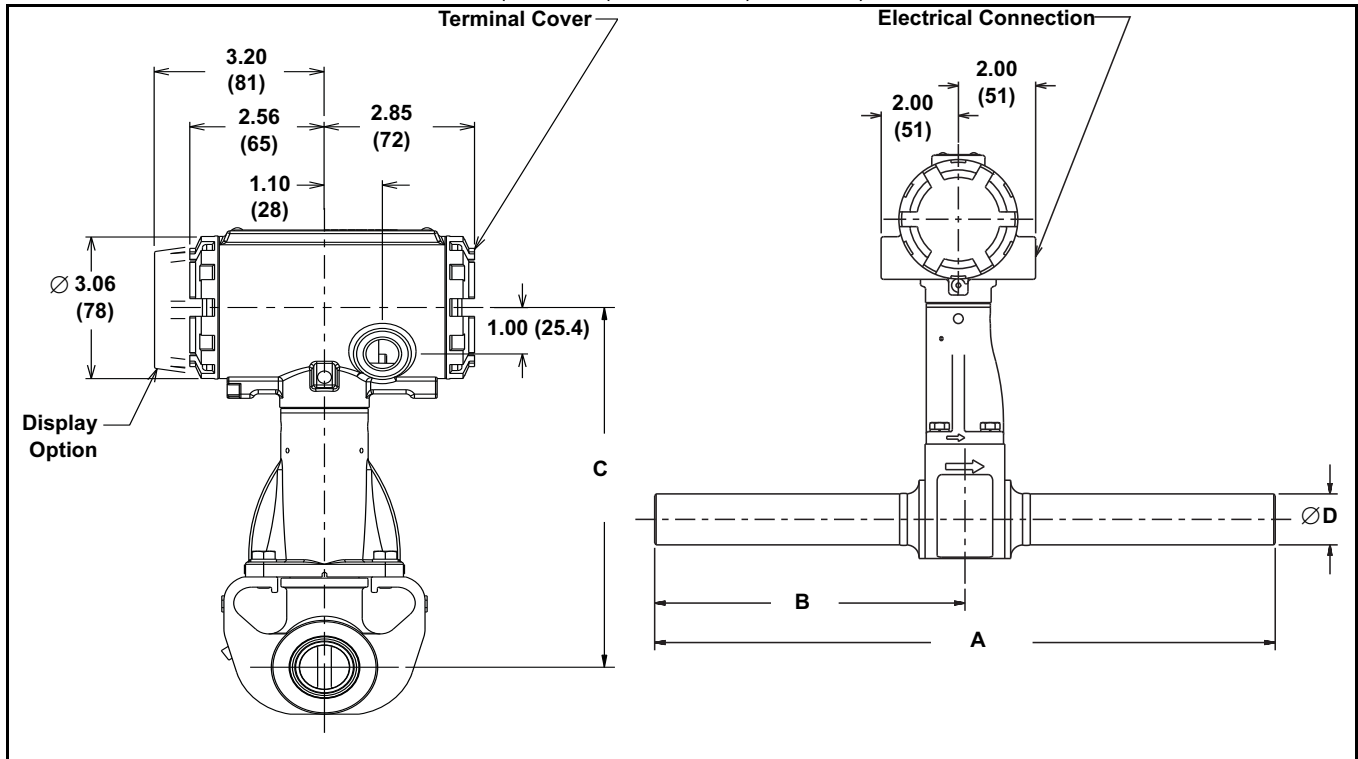

TABLE 27. Vortex weld-end style flowmeter  
 (1/2 - 4 in. (15 - 100 mm) line sizes)

Nominal Size	A ± .10 in. (2.5 mm)	B ± .05 in. (1.3 mm)	C ± .20 in. (5.1 mm)	Diameter D ± .031 in. (0.79 mm)
0.5 in.	16.0 in. (406)	8.0 in. (203)	7.63 in. (194)	.840 in. (21.34)
1 in.	16.0 in. (406)	8.0 in. (203)	7.74 in. (197)	1.315 in. (33.40)
1.5 in.	16.0 in. (406)	8.0 in. (203)	8.14 in. (207)	1.900 in. (48.26)
2 in.	16.0 in. (406)	8.0 in. (203)	8.49 in. (216)	2.375 in. (60.33)
3 in.	16.0 in. (406)	8.0 in. (203)	9.05 in. (230)	3.500 in. (88.90)
4 in.	16.0 in. (406)	8.0 in. (203)	9.60 in. (244)	4.500 in. (114.30)



**Product Data Sheet**

00813-0100-4004, Rev FA  
Catalog 2008 - 2009

**Rosemount 8800D**

FIGURE 8. Dimensional Drawings for Remote Mount Transmitters.

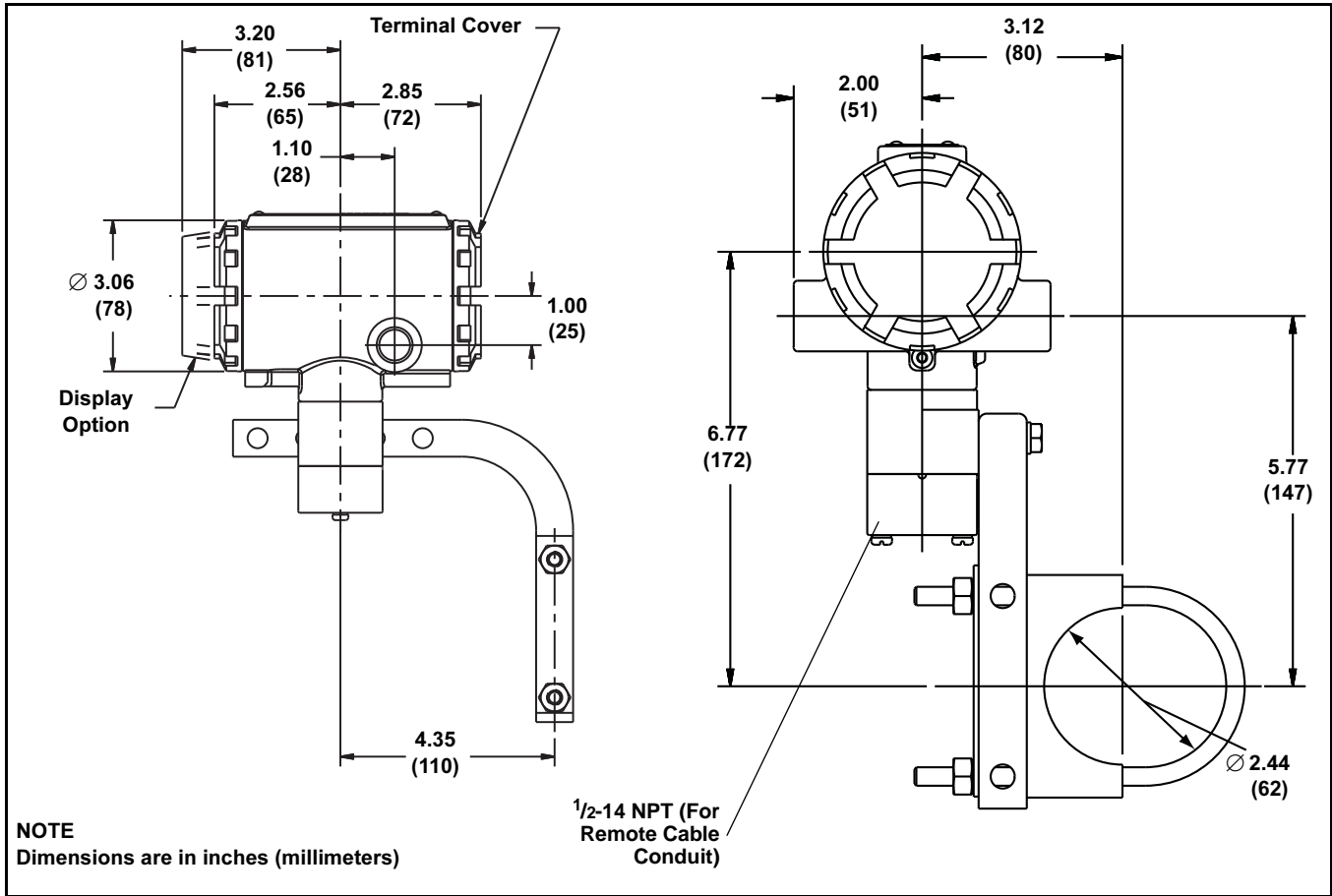

FIGURE 9. Dimensional Drawings for Remote Mount Wafer-Style Flowmeters  
 (1/2-through 8 in./15 through 200 mm Line Sizes)

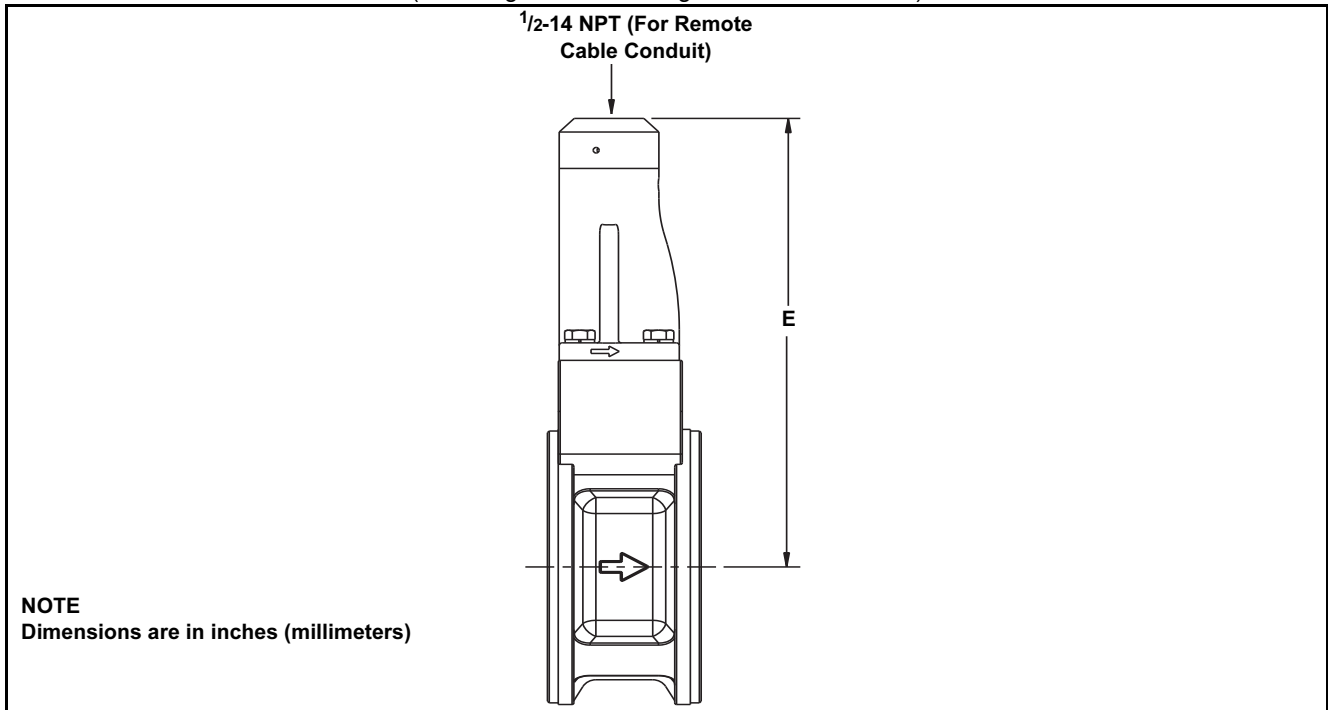

TABLE 28. Rosemount 8800D Wafer-Style Meter

Nominal Size in. (mm)	E Wafer Style in. (mm)
1/2 (15)	6.4 (163)
1 (25)	6.5 (165)
1 1/2 (40)	6.9 (175)
2 (50)	7.6 (193)
3 (80)	8.3 (211)
4 (100)	9.2 (234)
6 (150)	9.5 (241)
8 (200)	10.4 (264)

**Product Data Sheet**

00813-0100-4004, Rev FA  
 Catalog 2008 - 2009

**Rosemount 8800D**

FIGURE 10. Dimensional Drawings for Flanged-and Dual Sensor Flanged-Style Remote Mount Flowmeters  
 (1/2-through 12 in./15 through 300 mm Line Sizes)

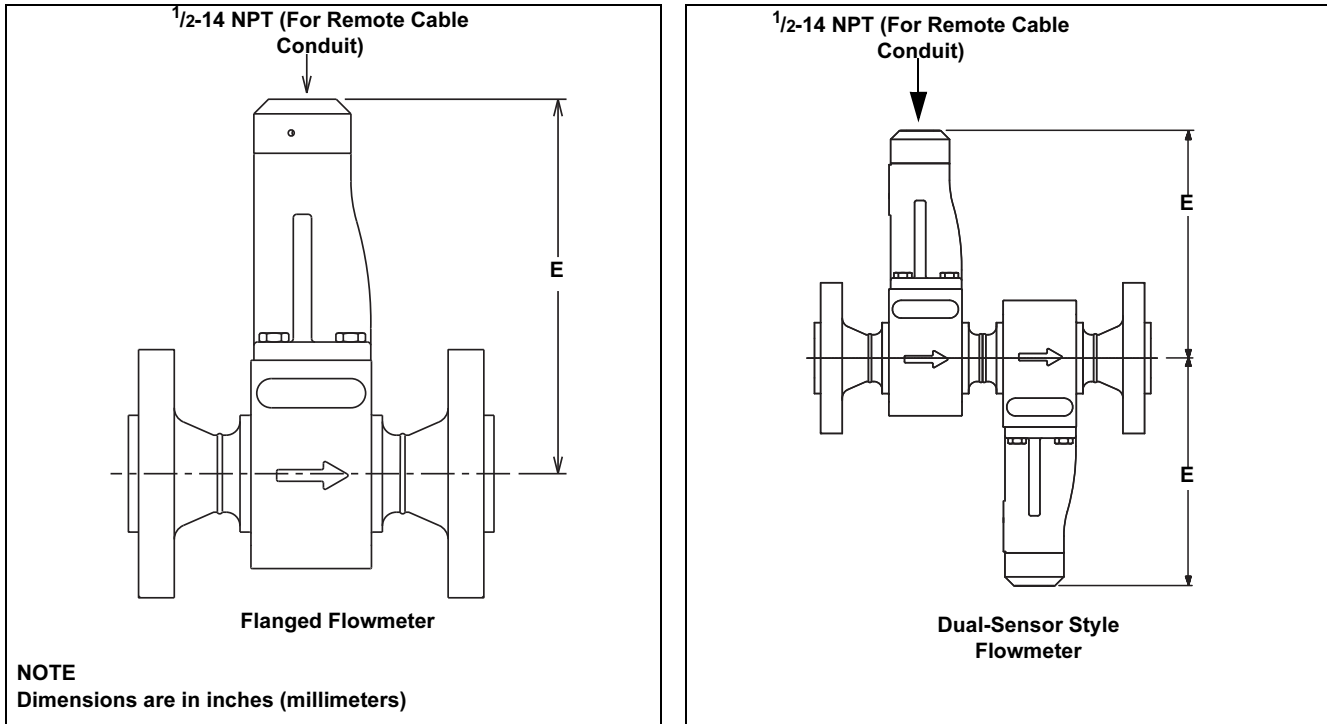

TABLE 29. Remote Mount, Flanged-and Dual Sensor Flowmeter Dimensions

Nominal Size in. (mm)	E Flange Style in. (mm)
1/2 (15)	6.4 (162)
1 (25)	6.5 (165)
1 1/2 (40)	6.8 (173)
2 (50)	7.2 (183)
3 (80)	7.8 (198)
4 (100)	8.3 (211)
6 (150)	9.5 (241)
8 (200)	10.4 (264)
10 (250)	11.4 (290)
12 (300)	12.3 (313)

## Ordering Information

Model	Product Description
8800D	Vortex Flowmeter
Code	Meter Style
W	Wafer style
F	Flanged style
R	Reducer Style (Flanged style only)
D	Dual-sensor style (Flanged style only)
Code	Line Size
005	1/2 in. (15 mm) (Not available for Rosemount 8800DR)
010	1 in. (25 mm)
015	1 1/2 Inches (40 mm)
020	2 Inches (50 mm)
030	3 Inches (80 mm)
040	4 Inches (100 mm)
060	6 Inches (150 mm)
080	8 Inches (200 mm)
100	10 Inches (250mm)
120	12 Inches (300mm)
Code	Wetted Materials
S	316L wrought stainless and CF-3M cast stainless
H	UNS N06022 wrought Nickel Alloy; CW2M cast Nickel Alloy <i>Note: See Table 29 on page 47</i>
Other wetted materials are available. Consult factory for details.	
Code	Flange or Alignment Ring Size
A1	ASME B16.5 (ANSI) RF Class 150
A3	ASME B16.5 (ANSI) RF Class 300
A6	ASME B16.5 (ANSI) RF Class 600
A7 <sup>(1)</sup>	ASME B16.5 (ANSI) RF Class 900
A8 <sup>(2)</sup>	ASME B16.5 (ANSI) RF Class 1500
B1	ASME B16.5 (ANSI) RTJ Class 150 for flange-style only
B3	ASME B16.5 (ANSI) RTJ Class 300 for flange-style only
B6	ASME B16.5 (ANSI) RTJ Class 600 for flange-style only
B7 <sup>(1)</sup>	ASME B16.5 (ANSI) RTJ Class 900 for flange-style only
B8 <sup>(2)</sup>	ASME B16.5 (ANSI) RTJ Class 1500 for flange-style only
C1	ASME B16.5 (ANSI) RF Class 150, smooth finish
C3	ASME B16.5 (ANSI) RF Class 300, smooth finish
C6	ASME B16.5 (ANSI) RF Class 600, smooth finish
C7 <sup>(1)</sup>	ASME B16.5 (ANSI) RF Class 900, smooth finish
D0	DIN PN 10 2526-Type D
D1	DIN PN 16 (PN 10/16 for wafer-style)2526-Type D
D2	DIN PN 25 2526-Type D
D3	DIN PN 40 (PN 25/40 for wafer-style) 2526-Type D
D4	DIN PN 64 2526-Type D
D6	DIN PN 100 2526-Type D
D7 <sup>(1)</sup>	DIN PN 160 2526-Type D
G0	DIN PN 10 2512-Type N for flange-style only
G1	DIN PN 16 2512-Type N for flange-style only
G2	DIN PN 25 2512-Type N for flange-style only
G3	DIN PN 40 2512-Type N for flange-style only
G4	DIN PN 64 2512-Type N for flange-style only
G6	DIN PN 100 2512-Type N for flange-style only
G7 <sup>(1)</sup>	DIN PN 160 2512-Type N for flange-style only

Continued on Next Page

## Product Data Sheet

00813-0100-4004, Rev FA

Catalog 2008 - 2009

# Rosemount 8800D

<b>Code</b>	
<b>Flange or Alignment Ring Size</b>	
H0	DIN PN 10 2526-Type E
H1	DIN PN 16 (PN 10/16 for wafer-style) 2526-Type E
H2	DIN PN 25 2526-Type E
H3	DIN PN 40 (PN 25/40 for wafer-style) 2526-Type E
H4	DIN PN 64 2526-Type E
H6	DIN PN 100 2526-Type E
H7 <sup>(1)</sup>	DIN PN 160 2526-Type E
J1	JIS 10K
J2	JIS 20K
J4	JIS 40K
W1 <sup>(3)</sup>	Weld End, Schedule 10S
W4 <sup>(3)</sup>	Weld End, Schedule 40S
W8 <sup>(3)</sup>	Weld End, Schedule 80S
W9 <sup>(3)</sup>	Weld End, Schedule 160S
<b>Code</b>	
<b>Sensor Process Temperature Range</b>	
N	Standard: -40 to 450°F (-40 to 232°C)
E	Extended: -330 to 800°F (-200 to 427°C)
<b>Code</b>	
<b>Conduit Entry</b>	
1	1/2 -14 NPT
2	M20 × 1.5
3	PG 13.5
4	G 1/2 (One Conduit Entry)
5	G 1/2 (Two Conduit Entries)
<b>Code</b>	
<b>Outputs</b>	
D	4-20 mA digital electronics (HART <sup>®</sup> protocol)
P	4-20 mA digital electronics (HART <sup>®</sup> protocol) with scaled pulse
F <sup>(4)</sup>	FOUNDATION fieldbus digital signal
<b>Code</b>	
<b>Calibration</b>	
1	Flow calibration

Continued On Next Page

# Rosemount 8800D

## Product Data Sheet

00813-0100-4004, Rev FA

Catalog 2008 - 2009

Code	Options
	<b>Multivariable Options</b>
MTA <sup>(5)</sup>	Multivariable output with Integral Temperature Sensor
	<b>Hazardous Locations Certifications</b>
E5	FM Explosion-proof, Dust Ignition-proof
I5	FM Intrinsically Safe, Division 2
IE	FM FISCO Intrinsically Safe <sup>(6)</sup>
K5	FM Explosion-proof, Dust Ignition-proof, Intrinsically Safe, Division 2
E6	CSA Explosion-proof, Dust Ignition-proof, Division 2
I6	CSA Intrinsically Safe
IF	CSA FISCO Intrinsically Safe <sup>(6)</sup>
K6	CSA Explosion-proof, Dust Ignition-proof, Intrinsically Safe, Division 2
KB	FM and CSA Explosion-proof, Dust Ignition-proof, Intrinsically Safe, Division 2
E1	ATEX Flameproof
I1	ATEX Intrinsic Safety
N1	ATEX Type n
ND	ATEX Dust
IA	ATEX FISCO Intrinsic Safety <sup>(6)</sup>
K1	ATEX Flameproof, Intrinsic Safety, Type n, Dust
E7	IECEX Flameproof
I7	IECEX Intrinsic Safety
IG	IECEX FISCO Intrinsic Safety <sup>(6)</sup>
N7	IECEX Type n
K7	IECEX Flameproof, Intrinsic Safety, Type n
E3	China Flameproof
I3	China Intrinsic Safety
N3	China Type n
IH	China FISCO/FNICO Intrinsic Safety <sup>(6)</sup>
K3	China Flameproof, Intrinsic Safety, Type n
E4 <sup>(7)</sup>	TIIS Flameproof
	<b>Plantweb Functionality</b>
A01	Basic Control: One Proportional/Integral/Derivative (PID) Function Block
	<b>Conduit Electrical Connector</b>
GE <sup>(8)</sup>	M12, 4-pin, Male Connector ( <i>eurofast</i> <sup>®</sup> )
GM <sup>(8)</sup>	A size Mini, 4-pin, Male Connector ( <i>minifast</i> <sup>®</sup> )
	<b>Other Options</b>
M5	LCD indicator
P2	Cleaning for special services
C4 <sup>(9)</sup>	NAMUR alarm and saturation values, high alarm
CN <sup>(9)</sup>	NAMUR alarm and saturation values, low alarm
R10	Remote electronics with 10 ft (3,0 m) cable
R20	Remote electronics with 20 ft (6,1 m) cable
R30	Remote electronics with 30 ft (9,1 m) cable
RXX <sup>(10)</sup>	Remote electronics with customer-specified cable length (up to 75 ft (23 m) maximum)
T1	Transient protection terminal block
V5 <sup>(11)</sup>	External ground screw assembly
	<b>Certification Options</b>
Q4	Calibration data sheet per ISO 10474 3.1B and EN 10204 3.1
Q8	Material traceability certification per ISO 10474 3.1B and EN 10204 3.1
Q14 <sup>(12)</sup>	German TRB 801 Nr.45 certification per ISO 10474 3.1B and EN 10204 3.1
Q25	NACE MR0103 Certificate of Compliance
Q69 <sup>(13)</sup>	Inspection certificate weld examination (wafer) per ISO 10474 3.1B and EN 10204 3.1
Q70	Inspection certificate weld examination (flanged) per ISO 10474 3.1B and EN 10204 3.1
Q71	Inspection certification weld examination (flanged) per ISO 10474 3.1B (includes x-rays) and EN 10204 3.1

Continued On Next Page

# Product Data Sheet

00813-0100-4004, Rev FA

Catalog 2008 - 2009

# Rosemount 8800D

Code	Quick Installation Guide (QIG) Language Options (Default is English)
YA	Danish QIG
YB	Hungarian QIG
YC	Czech QIG
YD	Dutch QIG
YF	French QIG
YG	German QIG
YH	Finnish QIG
YI	Italian QIG
YM	Mandarin QIG
YN	Norwegian QIG
YO	Polish QIG
YP	Portuguese QIG
YR	Russian QIG
YS	Spanish QIG
YW	Swedish QIG

**Typical Model Number: 8800D F 020 S A1 N 1 D 1 M5**

- (1) Available on flanged and dual style meters from 1/2" - 8" (15-200 mm) and Reducer style meters from 1" - 6" (25-150 mm).
- (2) Only available for stainless steel flange and dual style meters from 1" - 8" (25-200 mm).
- (3) W1, W4, W8, and W9 are only available with Meter Style F from 1/2 in. (15 mm) to 4 in. (100 mm) in SST.
- (4) Includes two analog input (AI) function blocks, 1 Integrator (INT) function block, and Backup Link Active Scheduler.
- (5) Available in Stainless Steel only. Available with Rosemount 8800DF from 2-in (50 mm) through 12 in. (300 mm). Available with 8800DR from 3-in (80 mm) through 12-in (300 mm). Not available with 8800DW or 8800DD. Not available with flange codes A7, A8, B7, B8, C7, C8, D7, D8, G7, G8, H7, H8. Not available with FOUNDATION fieldbus.
- (6) Fieldbus Intrinsic Safe Concept available with output code F (FOUNDATION fieldbus digital signal).
- (7) TIIS Flameproof Approval requires G<sup>1</sup>/2 conduit entry.
- (8) Not available with certain hazardous location certifications. Contact a Rosemount representative for details.
- (9) NAMUR compliant operation and the alarm latch options are pre-set at the factory and can be changed to standard operation in the field.
- (10) XX is a customer specified length in feet.
- (11) V5 only available with no approval, it is standard with the other approvals.
- (12) Q14 is not available with flange codes A7, A8, B7, B8, C7, D7, G7, H7, 10in.-12in. meters, and 8800DR Reducer Vortex.
- (13) Q69 available for all Nickel Alloy wafers and stainless steel wafers in line sizes 1/2 in. (15 mm), 6 in. (150 mm), and 8 in. (200 mm).

TABLE 29. Method of Construction for the 8800DF in Nickel Alloy.

Line Size	A1	A3	A6	A7	D1	D3	D4	D6	D7
1/2 (15)	C	C	C	W	W	W	NA	W	W
1 (25)	C	C	C	W	W	W	NA	W	W
1 1/2 (40)	C	C	C	W	W	W	NA	W	W
2 (50)	C	C	C	W	C	C	W	W	W
3 (80)	C	C	C	W	C	C	W	W	W
4 (100)	C	C	C	W	C	C	W	W	W
6 (150)	W	W	W	CF	W	W	W	W	CF
8 (200)	W	W	W	CF	W	W	W	W	CF
10 (250)	W	W	W	NA	W	W	W	W	NA
12 (300)	W	W	W	NA	W	W	W	W	NA

C = Nickel Alloy collar and 316 SST lap flange. If weld neck flange is required, V0022 can be ordered.

W = Nickel Alloy weld neck flange.

CF = Consult Factory

NA = Not Available

All 8800DR Reducer Vortex Meters with Nickel Alloy materials of construction use weld neck flanges.

Flange codes other than those listed in Table 29 all use weld neck flanges.

*Standard Terms and Conditions of Sale can be found at [www.rosemount.com/terms\\_of\\_sale](http://www.rosemount.com/terms_of_sale)  
The Emerson logo is a trade mark and service mark of Emerson Electric Co.  
Rosemount and the Rosemount logotype are registered trademarks of Rosemount Inc.  
PlantWeb is a mark of one of the Emerson Process Management companies.  
All other marks are the property of their respective owners.*

*Approved by the Committee of Russian Federation for Standardization, Metrology and Certification (the Gosstandart of Russia) and registered in the Russian State Register of measuring instruments.  
Reducer Vortex is a trademark of Rosemount Inc.  
MultiVariable (MV) is a trademark of Rosemount Inc.  
Annubar is a registered trademark of Dieterich Standard Inc.  
Mass ProBar and ProBar are trademarks of Dieterich Standard Inc.  
HART is a registered trademark of the HART Communication Foundation.  
FOUNDATION is a trademark of the Fieldbus Foundation.  
Cover Photo: 8800-8800k921*



## Emerson Process Management

### Rosemount Inc.

8200 Market Boulevard  
Chanhassen, MN 55317 USA  
T 1-800-999-9307  
T (International) (952) 906-8888  
F (952) 949-7001

[www.rosemount.com](http://www.rosemount.com)



### Emerson Process Management Flow

Neonstraat 1  
6718 WX Ede  
The Netherlands  
T +31 (0)318 495555  
F +31(0) 318 495556

### Emerson Process Management Asia

#### Pacific Private Limited

1 Pandan Crescent  
Singapore 128461  
T (65) 777 8211  
F (65) 777 0947  
Enquiries@AP.EmersonProcess.com



**EMERSON**  
Process Management